

1920 R[®]
MADE IN ITALY



AUTHENTICLIVING

Linee sinuose ed eleganti in grado di stupire per la fattura e per il pregio dei materiali utilizzati, naturali ed autentici come il legno massello di noce e la pelle. Riva 1920 lancia una nuova collezione di arredi in collaborazione con Automobili Lamborghini. Incontro di tradizione e innovazione, straordinaria cura per i dettagli, sapienza artigianale, passione e design sono alla base della collaborazione tra due grandi eccellenze produttive italiane. Karim Rashid, designer riconosciuto a livello internazionale, firma l'intera collezione fondendo, con la sua sorprendente personalità, i mondi Riva 1920 e Lamborghini.

Characterized by sinuous and stylish shapes, able to amaze thanks to fine workmanship and the quality of natural and genuine materials, such as solid walnut and leather.

Riva 1920 presents a new furniture collection in cooperation with Automobili Lamborghini.

Tradition, innovation, excellence are at the base of this cooperation between two outstanding Italian companies. The entire collection is signed by Karim Rashid, a prominent and internationally renowned designer, who thanks to his own distinctive mark has been able to merge the world of Riva 1920 and Lamborghini.

Riva 1920 è una realtà produttiva fatta di tradizioni, cultura, creatività ed innovazione. Un'azienda dove l'artigianalità si combina con il progresso e la tecnologia, dove il design esalta le idee, dove l'attenzione e la cura per i dettagli danno vita a prodotti unici e senza tempo, con una grande personalità.

Riva 1920 is a manufacturing company made of traditions, culture, creativity and innovation. A company where craft skills and values combine with progress and cutting-edge technology, where the design and the attention to detail create something unique, timeless and truly special.









Produciamo super sportive capaci di fare sognare, molte sono diventate icone, tutte incarnano valori che vanno oltre la pura funzionalità della vettura, da sempre. Siamo italiani, ricerchiamo l'eccellenza e crediamo che il nostro DNA possa essere interpretato in ogni contesto, per creare opere senza tempo.

We produce super sports cars that are the subject of dreams, many have become icons. They embody values that go beyond the simple functionality of a vehicle, ever since. We are Italian, we look for excellence and believe that our DNA can be translated in each context, creating timeless masterpieces.





L'Italia ha compreso la centralità del design già 75 anni fa, molto prima che il resto mondo ne riconoscesse il ruolo fondamentale. Senza brand come Riva 1920 e Lamborghini il design non sarebbe mai diventato così diffuso, onnipresente, sperimentale e di altissima qualità. Entrambe le aziende sono mosse da una grande passione e da una costante ricerca in favore dell'innovazione e della bellezza, da qui ho tratto la mia ispirazione e mi sono concentrato su una collezione semplice, minimalista ed estremamente sensuale.

Italy understood that Design is a public subject 75 years ago, long before the world accepted it. Without companies like Riva1920 and Lamborghini design would have never become ubiquitous, omnipresent, experimental yet of the highest quality. The passion from both companies with their desirous need for innovation and beauty inspired me to focus on minimal simple yet a sensual collection.

fantini





A
P
A
S
S
I
O
N
D
R
I
V
E
N
L
I
F
E















LEGNO | WOOD



NOCE OLIO | WALNUT OIL

Finitura: a base di olio/cera naturale di origine vegetale con estratti di pino.
Finish: base of oil / natural wax of vegetable origin with pine extracts.

SPEED

TAVOLO · TABLE

Tavolo completamente realizzato in legno massello con top a liste incollate e bordi smussati caratterizzato da una gamba asimmetrica con base d'appoggio posizionata lateralmente.

Table completely made of solid wood with table top made of glued lists and beveled edges, characterized by an asymmetrical leg with base positioned laterally.

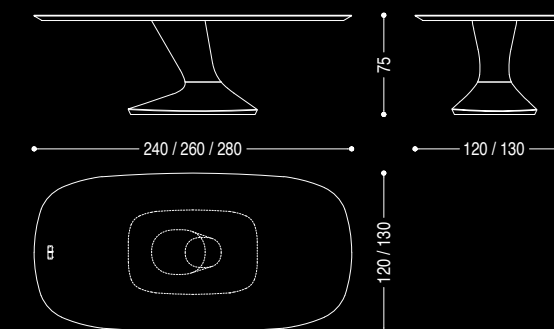













KLUTCH

SEDIA · CHAIR

Sedia imbottita e rivestita in pelle con cuciture a vista. Dalle forme sinuose ed avvolgenti è dotata di struttura sagomata in legno massello.

Upholstered chair, covered with leather with visible stitching with sinuous and enveloping forms, with a shaped structure made of solid wood.

LEGNO | WOOD



NOCE OLIO | WALNUT OIL

Finitura: a base di olio/cera naturale di origine vegetale con estratti di pino.
Finish: base of oil / natural wax of vegetable origin with pine extracts.

PELLE | LEATHER



CAMOSCIO 27 DAINO



CAMOSCIO 26 GRIGIO



CAMOSCIO 10 NERO

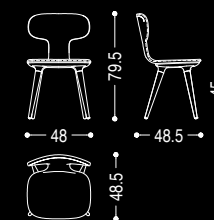















KLIP

SCRIVANIA · DESK

Scrivania caratterizzata da linee morbide e sinuose si compone di un piano d'appoggio in legno massello e frontali rivestiti di cuoietto. Dotata di pratica cassetiera composta da tre cassetti assemblati con incastri a coda di rondine e scanso laterale per apertura.

Desk characterized by smooth flowing lines and consisting of a top made of solid wood and drawer fronts covered with leather. It is equipped with a practical chest of drawers composed of three drawers assembled with dovetail joints and lateral groove for opening.

LEGNO | WOOD



NOCE OLIO | WALNUT OIL

Finitura: a base di olio/cera naturale di origine vegetale con estratti di pino.

Finish: base of oil / natural wax of vegetable origin with pine extracts.

PELLE | LEATHER

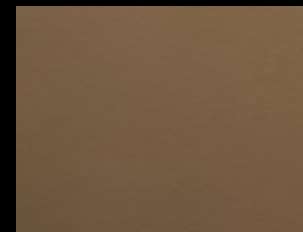

OLIMPIA CT 009 TORTORA

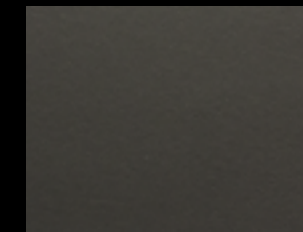

OLIMPIA CT 018 ANTRACITE

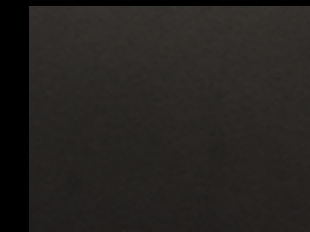

OLIMPIA CT 017 NERO

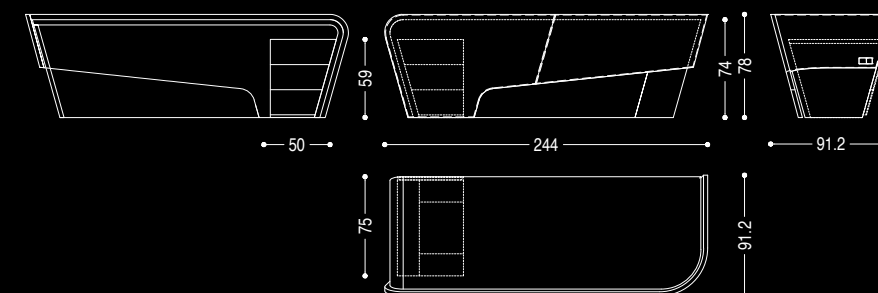













FINESSE

LIBRERIA · SHELF

Libreria realizzata in legno massello, si caratterizza per montanti asimmetrici in multistrato curvato e sagomato rivestiti in cuoio nei quali si innestano 6 mensole in legno massello di noce, spessore 5cm.

Shelf made of solid wood, it is characterized by asymmetrical supports in curved and shaped multilayer wood panels covered with leather, in which are fitted six shelves made of solid walnut, 5cm thickness.

LEGNO | WOOD



NOCE OLIO | WALNUT OIL

Finitura: a base di olio/cera naturale di origine vegetale con estratti di pino.
Finish: base of oil / natural wax of vegetable origin with pine extracts.

PELLE | LEATHER

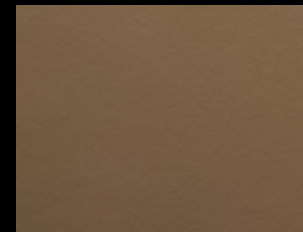

OLIMPIA CT 009 TORTORA

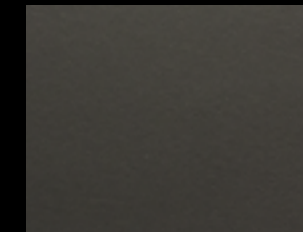

OLIMPIA CT 018 ANTRACITE

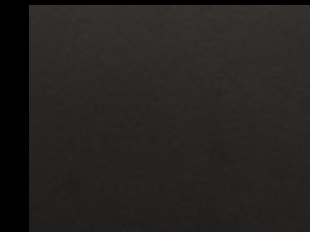

OLIMPIA CT 017 NERO

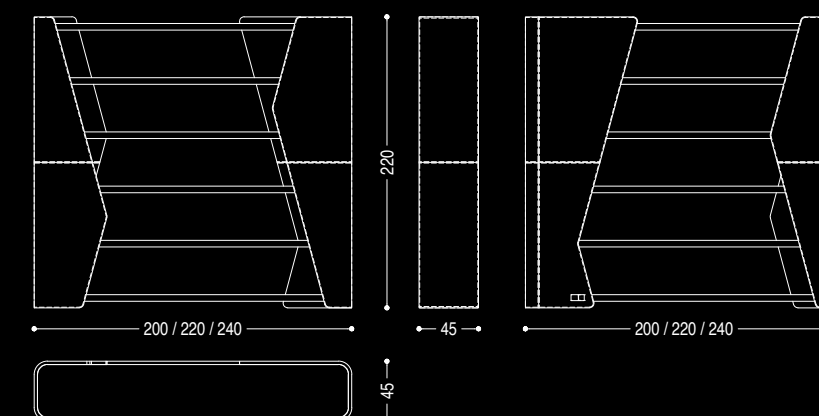















DYNAMIK

DIVANO · SOFA

Divano dotato di scocca in legno con mensola d'appoggio a correre lungo tutto il perimetro. Cuscini unici per seduta e schienale contraddistinti da cuciture a vista.

Sofa with wooden shell with support shelf running along the entire perimeter. Unique cushions for seat and back characterized by visible stitching.

LEGNO | WOOD



NOCE OLIO | WALNUT OIL

Finitura: a base di olio/cera naturale di origine vegetale con estratti di pino.
Finish: base of oil / natural wax of vegetable origin with pine extracts.

PELLE | LEATHER



CAMOSCIO 27 DAINO



CAMOSCIO 26 GRIGIO



CAMOSCIO 10 NERO

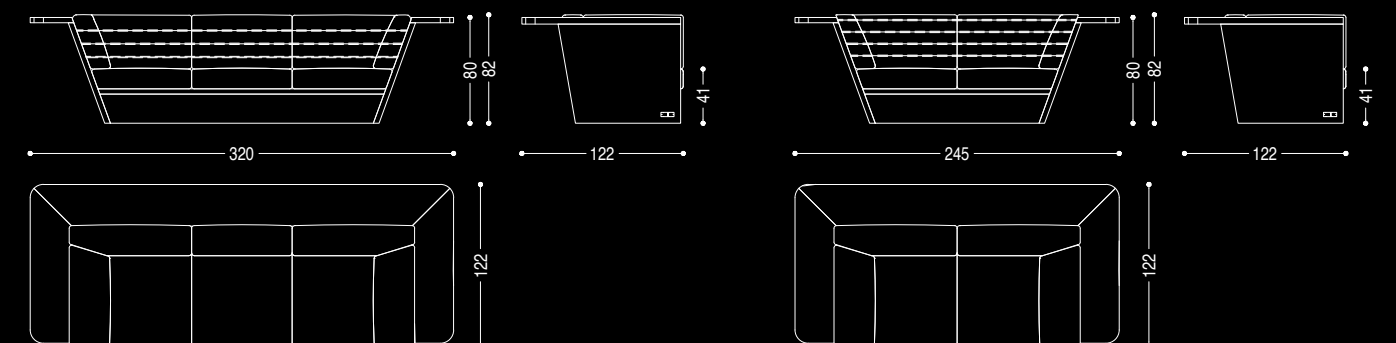



AUTHENTIC LIVING

ART DIRECTION

2B-AHEAD

PHOTO

MARCO BELLO

STYLING

PAOLA NEGRONI

MODELS

ALEXANDRE SCHUSTER

BRUNILDE CARELLA

PRINT 2017

LA GRAFICA · CANTÚ

THANKS TO

COLLEZIONE AUTOMOBILI LAMBORGHINI · FOR SELECTED CLOTHING AND FASHION ACCESSORIES

AUTOMOBILI LAMBORGHINI · CAR MODEL HURACÁN RWD COUPÉ

Le tecniche di stampa non consentono una perfetta riproduzione delle tonalità di colore, che vanno pertanto considerate come puramente indicative. Anche le illustrazioni e descrizioni presentate si intendono fornite a titolo indicativo. L' Azienda si riserva per tanto di apportare, in qualsiasi momento e senza preavviso, quelle modifiche che ritenesse utili per qualsiasi esigenza di carattere produttivo e commerciale.

Printing does not allow any perfect colour reproduction, therefore colours in this catalogue are not binding. Pictures and descriptions are not binding as well. The company reserves itself the right to introduce any possible necessary production or marketing change at any time without any previous notice.

"I marchi, copyright e i disegni e i modelli relativi ad Automobili Lamborghini, Automobili Lamborghini con il toro e lo scudo sono utilizzati sotto licenza di Automobili Lamborghini S.p.A., Italia."

"The trademarks, copyrights and design rights in and associated with Automobili Lamborghini, Automobili Lamborghini with Bull and Shield Device are used under licence from Automobili Lamborghini S.p.A., Italy"

RIVA

Industria Mobili SPA

T. +39 031 73 30 94

F. +39 031 73 34 13

riva1920@riva1920.it

www.riva1920.it

Show Room Riva1920

Museo del Legno

Via Milano, 110

22063 Cantù

Como · Italy