

OPERA



“L’OPERA
NON È CHE UN ITINERARIO”.

Joseph Joubert

“The work
is just the route”.

“La obra
es nada más que un itinerario”.

“L’oeuvre
c’est que un itinéraire”.

“Опера
это не что иное, как маршрут”.



Mentre in ambito internazionale l'Opera è una rappresentazione teatrale di un testo cantato ed accompagnato da musica, in Italiano ha molteplici significati: tra i principali sicuramente c'è sia l'attività diretta a un fine o che comunque produce un determinato effetto, che il risultato, l'effetto di un'attività, di un'azione materiale. Opera è anche il frutto del lavoro artistico o intellettuale; quindi per Opera possiamo intendere un processo, intellettuale prima e lavorativo poi, che si tramuta in un risultato. Opera è una non collezione, cioè non è una raccolta di oggetti omogenei da adattare ai gusti del mercato, ma al contrario, non seguendo l'approccio tradizionale, si evolve controcorrente. Interpretando bisogni concreti, Newform Ufficio propone l'innesto di vari tipologie di piani, abbinandoli alla struttura di alluminio, filo conduttore del progetto. L'interazione tra piani e struttura, design e robustezza, stile e rigore, produce esiti inaspettati paragonabili per certi versi al principio dei vasi comunicanti. Cioè a quel principio fisico secondo il quale un liquido contenuto in due o più contenitori comunicanti tra loro, in presenza di gravità, raggiunge lo stesso livello dando vita ad un'unica superficie equipotenziale. Figurativamente è possibile sostenere, quindi, che per Opera valga lo stesso concetto, innalzando e nel contempo riequilibrando il livello anche di collezioni preesistenti, apportandone nuova linfa e vigore.

While in the international environment Opera is a theatrical play of a singed text accompanied by music, in the Italian language meanings could be different: among the most used ones there is the activity with its own aim or which produces a specific effect or the result, the effect or an activity, of a concrete action. Opera is also the result of an intellectual and artistic job; therefore with Opera we intend a process, intellectual first and working then, which turns into a result. Opera isn't a collection; in other words it is not a set of items to be adapted to the market's tastes but, on the contrary, out of the traditional approach, it goes against the stream: starting from real needs, Newform Ufficio mixes up different types of worktops, combining them with the aluminium structure, which is the theme of the project. The interaction between worktop and structure, design and durability, style and rigor gets to a final result approaching the idea of communicating pots. It is a physics principle stating that a liquid contained

in two or more pots communicating with each other, in the presence of gravity, gets levelled in a single surface. We can easily move this concept to Opera, enhancing and, in the same time, levelling existing collections, bringing new life and energy.

Mientras en el ámbito internacional la Opera es una representación teatral de un texto cantado y acompañado por la música, en italiano tiene múltiples significados: entre los principales seguramente hay tanto la actividad directa a un fin o que sin embargo produce un efecto determinado, que el resultado, el efecto de una actividad, de una acción material. Opera es también el fruto del trabajo artístico o intelectual; entonces por Opera podemos entender un proceso, primero intelectual, luego de trabajo, que luego se convierte en un resultado. Opera es una no colección, o sea no es un conjunto de objetos homogéneos para adaptar a los gustos del mercado, sino al contrario, sin seguir una aproximación tradicional, evoluciona contracorriente: interpretando necesidades concretas, Newform Ufficio propone la introducción de varias tipologías de planos, combinándolos con la estructura de aluminio, hilo conductor del proyecto. La interacción entre planos y estructura, diseño y robustez, estilo y rigor, produce éxitos inesperados comparables en algunas formas con el principio de los vasos comunicantes. Es decir aquel principio físico según el cual un líquido contenido en dos o más contenedores comunicantes entre sí, en presencia de gravedad, alcanza el mismo nivel generando una única superficie equipotencial. Figurativamente es posible argumentar, por lo tanto, que para Opera vale el mismo concepto, elevando y al mismo tiempo reequilibrando el nivel también de colecciones preesistentes, aportando nueva vida y vigor.

Si au niveau international l'Opera est une représentation théâtrale d'un texte chanté et accompagné par la musique, en langue italienne ce mot prend plusieurs significations : notamment l'activité directe pour un but ou que quand même produit un effet déterminé ainsi que le résultat, l'effet d'une activité, d'une action matérielle. Opera est même le fruit d'un travail artistique ou intellectuel; donc comme Opera on peut définir un processus intellectuel avant et de mise en œuvre après que sort dans un résultat. Opera est une non gamme, il s'agit pas d'un ensemble d'éléments

homogènes à adapter au gout du marché, mais à l'inverse, sans suivre l'approche traditionnel, évolue contre-courant: en interprétant besoins concrets, Newform Ufficio propose l'utilisation de différentes typologies de plateaux, en association à la structure en aluminium, fil rouge du projet. L'intégration entre plateaux et structure, design et solidité, style et rigueur, produit des résultats imprévus comparables pour certains aspects au principe des vases communicantes. Le principe pour lequel un liquide remplissant plusieurs récipients qui sont reliés entre eux, en présence de gravité, occupe la même hauteur dans chacun d'entre eux. Pour analogie donc on peut dire donc que pour Opera fonctionne le même concept, en rehaussant et au même temps en rééquilibrant le «niveau» des collections déjà existantes, en apportant nouvelle sève et vigueur.

ОПЕРА – это прежде всего, конечно же, театральное представление под музыку и пение, но в итальянском языке это слово имеет и другие значения: непосредственное действие с определенным завершением, результатом, дело, которое характеризуется завершенностью. ОПЕРА – это также плод художественного и интеллектуального труда, следовательно, ОПЕРУ мы можем представить, как интеллектуальный, а затем и рабочий процесс, завершённый в некоем результате. ОПЕРА - это не коллекция, т.е. это не сборник однородных элементов, адаптируемых к вкусам рынка, но скорее наоборот, это средство, которое оставляя в стороне привычные подходы, интерпретирует конкретные запросы. Newform Ufficio предлагает разные типы столешниц, сочетая их с алюминиевым каркасом, проводником всего проекта. Взаимосвязь между столешницей и каркасом, дизайном и прочностью, стилем и законом, производит неожиданный здесь эффект сообщающихся сосудов. Т.е., как и в сообщающихся сосудах жидкость всегда оказывается на одном уровне в разных местах, образуя некую потенциально единую поверхность, так и здесь, ОПЕРА, задаёт концепт, который поднимает и одновременно уравнивает и существующие уже коллекции, и новинки, всех одаривая новыми жизненными силами.





“Tra i tanti significati della parola Opera in lingua italiana, mi ha sempre colpito quello attinente al frutto del lavoro, artistico ed intellettuale in special modo. Tale definizione si addice perfettamente all’ideazione e realizzazione di questa struttura. In sintonia con l’Ufficio Tecnico Newform Ufficio come coordinatore di progetto ero partito con una collezione di tavoli, che si è via via evoluta in una collezione multitasking, includendo moduli utilizzabili in sale conferenze, sale congressi, aule didattiche, biblioteche ed uffici direzionali. La struttura portante del tavolo realizzata in fusione d’alluminio, la definirei un lavoro artistico, tanto era la complessità della forma. Lo sviluppo modulare dei piani abbinato alle variabili materiche e di finitura associato infine a soluzioni innovative per sale conferenze ed uffici direzionali è stato un duro banco di prova, ma visto il risultato conseguito, posso dire che ne è valsa la pena. Opera, quindi, pur studiato per soddisfare le necessità del mondo ufficio, vista la grazia delle forme e l’accuratezza nei dettagli è tuttavia un sistema valido anche per il mondo home, solitamente più esigente. In definitiva una bella idea ed un altro bel progetto Newform Ufficio”.

“Among the different meanings of the Italian word Opera, something has always attracted me is the one relating to a work result, especially artistically and intellectually. This definition perfectly fits the idea and structure set up. In line with Newform Ufficio Technical Department and as project coordinator I started with a collection of tables, soon evolving in a multitasking collection, including modules to be used in meeting rooms, conference rooms, classrooms, libraries and directional offices. The structure of the table achieved in aluminium fusion could be considered an artistic job for the complexity of the shape. It has been a tough but worth job to achieve the result of finding new solutions about modulating desktops with both material and finishing options as well as innovative solutions for conference rooms and directional offices. Opera, therefore, in spite of having been designed as a product for the office world, considering the grace of its shapes and the accuracy of the details, could be also considered as a product for the home world, normally more demanding. After all a good idea and another nice project from Newform Ufficio”.

“Entre los varios significados de la palabra Opera en italiano, siempre me ha llamado la atención lo que atañe el fruto del trabajo, artístico e intelectual

especialmente. Dicha definición se adapta perfectamente a la ideación y a la realización de esta estructura. En sintonía con el Newform Ufficio Technical Dept. como coordinador de proyectos había empezado con una colección de mesas, que poco a poco evolucionó en una colección multitasking, incluyendo módulos utilizables en salas de conferencias, salas de congresos, aulas didácticas, bibliotecas y oficinas ejecutivas. La estructura portante de la mesa realizada en fusión de aluminio, la definiría un trabajo artístico, dada la complejidad de la forma. El desarrollo modular de los planos combinado con las variables matéricas y de acabado asociadas por fin con soluciones innovadoras para salas de conferencias y oficinas ejecutivas ha sido un duro banco de pruebas, pero por el resultado conseguido, puedo decir que mereció la pena. Opera, por lo tanto, aunque estudiado para satisfacer las necesidades del mundo de la oficina, gracias a las formas y al cuidado al detalle es de todas maneras un sistema válido también para el mundo home, normalmente más exigente. En definitiva una buena idea y un otro buen proyecto Newform Ufficio”.

“Entre les plusieurs sens du mot Opera en Italien, il m’a toujours frappé celui en relation au résultat du travail, surtout artistique et intellectuel. Cette définition se conforme parfaitement all’idéation et à la réalisation de cette structure. En accord avec le Newform Ufficio Technical Dept. comme coordinateur du projet j’étais parti avec une gamme de tables, mais ça a évolué comme une gamme multitasking, avec modules utilisables en salles conférences, salles congrès, salles formation, bibliothèques et bureaux direction. La structure portante de la table, réalisé en fusion d’aluminium est un travail artistique, si on considère la complexité de la forme. Le développement modulaire des plateaux combiné avec les variantes matériaux et de finition et associé en fin à solutions innovants pour salles conférences et bureaux directions à été un difficile test, mais si on regarde le résultat, on peut dire que l’effort a été bien payé. Opera, donc, même si étudié pour satisfaire les nécessités du monde du bureau, en considérant la grâce des formes et le soin des détails est par contre un système valide pour le domaine home, un monde considéré d’habitude plus exigeante. En final une belle idée et un autre beau projet Newform Ufficio”.

“Среди множества значений слова ОПЕРА в итальянском языке меня



всегда особенно привлекало то, что относится к результату работы, особенно художественной или интеллектуальной. Данное определение, как нельзя лучше подходит к идее и к реализации предлагаемой структуры. В сотрудничестве с техническим отделом Newform Ufficio в качестве координатора проекта, изначально была запущена коллекция письменных столов, которая постепенно переросла в многофункциональный проект, включающий в себя модули для конференц-залов, залов конгрессов, студенческих аудиторий, библиотек и административных офисов. Структура стола из литого алюминия можно смело назвать произведением искусства, настолько сложна его форма. Развитие модулистики в сочетании с использованием различных материалов и отделок, в купе с инновационными предложениями для конферен-залов и офисов стало для нас серьёзным испытанием, но учитывая полученный результат, могу сказать, что игра стоила свеч. Opera таким образом разработана для удовлетворения потребностей офиса, а учитывая красоту форм и точность деталей является по-настоящему интересной так же и для мира home, который в свою очередь всегда более требовательный. В конечном счёте прекрасная идея и ещё один замечательный проект Newform Ufficio”.

Art Director Riccardo Vicenzetti

OPERA STRUCTURE

The protagonist



A suo agio in tutte le situazioni nonostante sia sempre al centro della scena con stile ed eleganza, tende a valorizzare ciò che lo circonda. La sua naturale allure non ha bisogno di preziosi e la sua struttura di profilo mostra il meglio di sé. 90-60-90? No, Opera è molto di più.

Passioni ed interessi: team-building, il musical, e lo spettacolo in generale.

At ease in all the situations although always at the centre of the scene with style and elegance, it brings out the surrounding. The profile shows it at best without the need of adding further precious features to its natural allure. 90-60-90? No, Opera is much more. Passions and interests: team-building, musical and the spectacle.

A gusto en todas las situaciones no obstante esté siempre en el centro de la escena, con estilo y elegancia tiende a valorar lo que la rodea. Su natural encanto no necesita alanzabas y su estructura de perfil muestra lo mejor de sí. 90-60-90? No, Opera es mucho más. Pasiones e intereses: team-building, el musical, y el espectáculo en general.

A l'aise dans toutes les situations, même si toujours au centre de la scène, avec style et élégance valorise ce qui est alentour. Sa naturelle allure ne nécessite pas de décorations et sa structure en vue de profil montre sa face la meilleure. 90-60-90? Non, Opera est bien plus que ça. Loisirs: team building, le musical, et le spectacle en général.

В стремлении к комфорту и вопреки всем ситуациям пребудет в центре сцены - стильно и элегантно, придавая ценность своему окружению. Её естественное благородство не нуждается в дополнении, профиль говорит сам за себя. 90-60-90? Нет, ОПЕРА больше этого. Увлечения и интересы: team-building, музыка, спектакль.

Giornalista di larga fama e grandi relazioni, vuole aprire la sua agenzia di stampa a Londra. Decisione maturata negli anni col crescere della sua insofferenza al mondo ed ai modi dell'informazione embedded. Passioni ed interessi: Gutenberg ed i caratteri di stampa medievali.

Wide known journalist, he wishes to open his own press agency in London. The decision originated from his intolerance to the world and the embedded information. Passions and interests: Gutenberg and the medieval printing characters.

Periodista de reconocido prestigio y relaciones excelentes, quiere abrir su agencia de prensa en Londres. Decisión adoptada a través de los años con el crecer de su intolerancia en el mundo y a las maneras de la información embedded. Pasiones e intereses: Gutenberg y los tipos de letras medievales.

Journaliste connu et avec des grandes relations, il voudrait ouvrir son agence à Londres. Décision prise pendant les dernières années par l'augmentation de l'intolérance au monde et aux méthodes de l'information embedded. Loisirs: Gutenberg et les caractères d'impression médiévaux.

Широкоизвестный журналист решает открыть своё издательское агенство в Лондоне. Решение, зрелее годами вместе с его нетерпимостью к миру и к методам обработки информации embedded. Увлечения и интересы: Гутенберг и средневековые шрифты.



FRANK
Journalist

BILL
Real Estate Agent

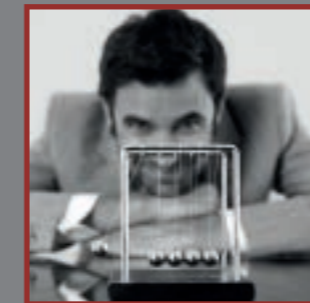

Immobiliariista da generazioni, molto quotato nella City per via una moltitudine di relazioni e prelezioni ereditate da suo padre. Informatore di Frank per tutto quello che di rilevante accade a Londra. Ha conosciuto Norman durante l'arredamento dell'hotel ed ha richiesto lo stesso arredamento nel suo ufficio dalla vista mozzafiato. Passioni ed interessi: psicologia e sociologia in generale, profondo conoscitore della comunicazione non verbale.

Real estate developer for generations, highly rated in the City for the valuable relationships inherited by his father. Frank's informer for everything relevant happening in London. He has previously met Norman while furnishing his breathtaking view office, when he was looking for something special and advised him for the renovation of the Congress Centre. Passions and interests: psychology and sociology, expert in nonverbal communication.

Agente inmobiliario de generaciones, altamente calificado en la City por medio de una multitud de relaciones y preleziones heredadas de su padre. Informador de Frank por todo lo relevante que pasa en Londres. Conoció a Norman hace algún tiempo en la decoración de su oficina con vistas espectaculares, cuando iba buscando algo comparable y lo sugirió por la reforma del centro de congresos. Pasiones e intereses: psicología y sociología en general, profundo conocedor de la comunicación no verbal.

Agent immobilier pour héritage, très apprécié dans la City pour le grand nombre de relations et prélezions héritées par son père. Informateur de Frank pour tout ce que arrive d'importante à Londres. Il est entré en contact avec Norman pour l'aménagement de son bureau avec une vue incroyable, pour l'étude d'une ambiance et aménagement pareilles, et comme consultant pour le renouvellement du centre congrès. Loisirs: psychologie et sociologie en générale, profonde connaissance de la communication non verbale.

Риэлтор из того поколения, которое очень ценится в Сити за множество полезных связей, унаследованных от отца. Информатор Франка относительно всего важнейшего, что происходит в Лондоне. Познакомился с Норманом некоторое время назад, когда обставлял свой шикарный офис и искал что-нибудь сопоставимое. Он его и рекомендовал для реконструкции зала конгрессов. Увлечения и интересы: Психология и Социология, глубокий знаток невербальной коммуникации.

Il Nord Europa come raggio d'azione, ama distinguersi lavorando con prodotti italiani di qualità. La sua maggiore abilità è quella di utilizzare i prodotti di cui si innamora nei contesti più svariati, venendo sempre ripagato dalla scelta. Passioni ed interessi: i mobili italiani di gusto e valore e la sua villa in Abruzzo, graziosa regione in centro Italia.

Most interested in Northern Europe market, he likes to work with high quality Italian products. His best feature is to use products he falls in love with. Passions and interests: high value Italian furniture and his villa in Abruzzo, region of the centre of Italy, one of the best place in the world to live the retirement according to the Huffington Post.

El Norte de Europa como radio de acción, ama destacarse trabajando con productos Italianos de calidad. Su mayor capacidad es la de utilizar los productos de los cuales se enamora en los contextos los más variados, quedando siempre recompensado por su elección. Pasiones e intereses: los muebles italianos de gusto y valos y su villa en Abruzzo, región del centro de Italia, una de las mejores localidades del mundo donde retirarse, según una reciente reseña del Huffington Post. Le Nord Europe comme zone d'activité, il aime se démarquer en travaillant avec produits Italiens de qualités. Son habilité la plus importante, utiliser les produits préférés dans les différents contextes, avec réussite du choix. Loisirs: les meubles italiens de gout et valeur, sa villa dans les Abruzzes, région du centre Italie, un de lieu les meilleurs au monde pour passer la retraite selon un dernier reportage de l'Huffington Post.

Северная Европа как театр действий. Предпочитает работать с качественной итальянской продукцией. Его искусство заключается в том, чтобы использовать такие материалы, в которые влюбляешься в самых невероятных случаях и всегда остаешься в выигрыше. Увлечения и интересы: стильная итальянская мебель и собственная вила в Абрुццо, в центральном регионе Италии, в одном из лучших мест мира, куда по опросу Huffington Post, лучше всего переехать жить, уйдя в отставку.



NORMAN
Architect

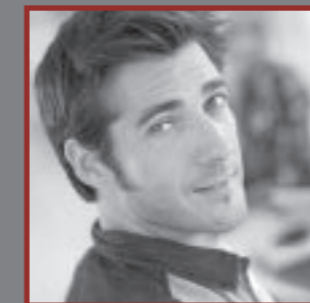

OLIVER
Scenographer

Amico berlinese di Norman, si occupa principalmente di cinema e teatro, talvolta di rappresentazioni storiche. Ambienterà gli uffici di Frank ispirandosi alle sue passioni affinché le lunghe giornate in redazione siano meno pesanti. Per una ricerca su testi antichi si recherà in una biblioteca che custodisce testi antichi. Passioni ed interessi: fotografia e natura, hobbies che lo portato spesso in Italia, ospite di Norman.

Norman's Berliner friend, he is mainly involved in cinema and theatre, sometimes with historical representations. He is going to refurbish Frank's offices being inspired by his passions so to lighten his hard days in the press office. He is going to find ancient texts in a Library specifically housing them. Passions and interests: photography and nature, hobbies which often take him to Italy, hosted by Norman.

Amigo Berlínés de Norman, se ocupa principalmente del cine y teatro, tal vez de representaciones históricas. Proyectará las oficinas de Frank inspirándose a su pasiones para que los largos días en la redacción sean menos peasadadas. Para una búsqueda sobre los textos antiguos irá a una Biblioteca que conserva textos antiguos. Pasiones e intereses: fotografía y la naturaleza, aficiones que lo llevan muchas veces a Italia, invitado de Norman.

Ami berlinoise à Norman, il s'occupe surtout de cinéma et théâtre, et de représentations historiques. Il créera l'ambiance du bureau de Frank en s'inspirant à ses passions au fin que les longues journées en rédaction soient moins lourdes. Il se dirigera dans une bibliothèque pour une recherche sur des textes antiques. Loisirs: photographie et nature, hobbies qui l'amènent très souvent en Italie, chez Norman.

Берлинский друг Норманна, занят, прежде всего, в кино и в театре, иногда историческими реконструкциями. Обставит офис Франка согласно своим представления, чтобы длинные дни в офисе не были такими тяжелыми. В поисках древних текстов найдет библиотеку, которая хранит старые рукописи. Увлечения и интересы: Фотография и природа – хобби, которое часто приводит его в Италию погостить у Норманна.

ATTO I

Conferenza

Conference Event

pag.12

ATTO II

Definizione
Del Progetto

Project
Definition

pag.22

ATTO III

Selezione Uffici
Presso
Agenzia Immobiliare

Office Selection In
Real Estate Agency

pag.30

ATTO IV

Studio
Dell'Architetto

Architect Facilities

pag.38

ATTO V

Uno Scenografo
In Scena

A Scenographer
On Stage

pag.48

ATTO VI

Ricerca
Nel Passato

Searching
In The Past

pag.56

ATTO VII

Seminario In Corso

Seminar
On The Way

pag.66

ATTO VIII

La Redazione
Al Lavoro

Editorial Staff
In Activity

pag.74

ATTO IX

Ben Fatto

Well Done

pag.82

ATTO I

Conferenza

Conference Event

Frank presiede la presentazione del progetto del nuovo ufficio stampa. Principi ispiratori: verifica delle notizie, protezione delle fonti, trasparenza verso il pubblico ed un tocco di originalità. La sala conferenze Opera si dimostra efficace ed efficiente.

Frank holds the presentation of the new press office. Guiding principles: checked news, protection of sources, transparency towards the public and a touch of originality. The Opera conference room proves to be effective and efficient.

Frank preside a la presentación del proyecto de la nueva oficina de prensa. Principios inspiradores: verificación de las noticias, protección de las fuentes, transparencia hacia el público y un toque de originalidad. La sala de conferencias Opera se demuestra eficaz y eficiente.

Frank préside la présentation du projet du nouveau bureau de presse. Principes inspireurs: vérifications des informations, protections des sources, transparence vers le public et une touche de originalité. La salle conférence Opera se révèle efficace et efficiente.

Франк председательствует на презентации проекта нового пресс-центра. Руководящие принципы: Верификация новостей – защита источников – общественная прозрачность и оригинальность. Конференц-зал ОПЕРА демонстрирует действенность и эффективность.











ATTO II

Definizione
Del Progetto

Project
Definition

Acquisire un immobile a Londra. I nostri protagonisti nella sala riunione del centro congressi definiscono gli obiettivi e le strategie. Una sola certezza: su Opera si può sempre contare.

Acquiring a property in London. Our protagonists of the meeting room and congress centre are defining objective and strategy. Only one certainty: you can always count on Opera.

Adquirir una propiedad en Londres. Nuestros protagonistas en la sala de reuniones del centro de congresos definen objetivos y estrategias. Solo una certeza: siempre se puede contar con Opera.

Acheter un immeuble à Londres. Nos protagonistes dans la salle réunion du centre congrès définissent objectif et stratégie. Une seule certitude: sur Opera on peut toujours y compter.

Приобрести недвижимость в Лондоне. Наши протагонисты в зале собраний конгресс-холла определяют цели и стратегию. Только есть одна определенность: на ОПЕРУ всегда можно рассчитывать.









ATTO III

Selezione Uffici

Presso

Agenzia Immobiliare

Office Selection In
Real Estate Agency

L'immobile è stato selezionato, la zona è centrale e prestigiosa. Il tavolo riunione e la libreria Opera si lasciano ammirare anche nella sala riunione di Bill e dei suoi uffici.

The building has been chosen, a central and prestigious area. Opera meeting table and bookcase are to be admired also in Bill's meeting room and in his offices.

La propiedad ha sido seleccionada, la zona central y prestigiosa. La mesa de reuniones y la librería Opera se dejan admirar también en la sala de reuniones de Bill y de sus oficinas.

L'immeuble a été choisi, en zone prestigieuse et centrale. La table réunion et l'armoire Opera se laissent découvrir dans la salle réunion de Bill et de ses bureaux.

Недвижимость выбрана – в престижном центре. Переговорный стол и шкаф ОПЕРА удивляют также в зале собраний Билла и в его офисе.









ATTO IV

Studio
Dell'Architetto

Architect Facilities

Frank apprezza il lay-out progettato per l'ufficio stampa. Norman da padrone di casa lo ha ospitato nel suo buen retiro, la cui vista del mare da una parte e la montagna dall'altra lo rende uno scenario unico. Opera si conferma protagonista versatile recitando il doppio ruolo di tavolo riunione e libreria.

Frank appreciates the press office lay-out. Norman is an excellent landlord in his villa viewing both the mountains in one side and the sea on the other side, setting up a unique scenary. Opera confirms to be a versatile protagonist playing a double role: meeting table and bookcase.

Frank aprecia el lay-out de la oficina de prensa. Norman es un excelente anfitrión en su buen retiro, cuya vista del mar por un lado y la montaña por el otro rinden el escenario único. Opera se confirma como un protagonista versátil desempeñando también un doble papel: mesa de reuniones y librería.

Frank apprécie le lay-out de son bureau de presse. Norman bon hôte dans son alcôve avec vue sur la mer d'une côté et sur la montagne de l'autre, pour un panorama unique. Opera se confirme protagoniste versatile en jouant un double rôle: table réunion et armoire.

Франк по достоинству оценивает планировку пресс-центра, Норманн – отличный хозяин дома, из которого с одной стороны открывается чудесный вид на море, с другой не менее прекрасный вид на горы – выстраивает уникальный план. ОПЕРА утверждается как протагонист, отмечая гибкость исполнения и двойной роли – переговорный стол и шкаф.











ATTO V

Uno Scenografo
In Scena

A Scenographer
On Stage

Oliver è stato contattato da Norman per dare un pizzico di storicità al nuovo Ufficio Stampa. Il tavolo riunione che Oliver utilizza come scrivania lo supporta pienamente.

Oliver has been contacted by Norman to give a hint of historic to the new Press Office – The meeting table Oliver is using as a desk is supporting the idea.

Oliver ha sido contactado por Norman para dar una pizca de historicidad a la nueva Oficina de Prensa. La mesa de reuniones que Oliver utiliza como escritorio lo soporta plenamente.

Oliver a été contacté par Norman pour donner un peu de gout historique à son nouveau bureau de presse. La table réunion que Olivier utilise lui donne plein support.

С Оливером связался Норманн, чтобы сказать об историчности нового пресс-центра – переговорный стол, который Оливер использует как письменный – подтверждает это полностью.





57 52 18 57 52 18 57 52 18 57 52 18
35 22 17

30°
31 25
3 12





ATTO VI

Ricerca
Nel Passato

Searching
In The Past

Un carattere speciale per un ufficio stampa di carattere. Un salto nel tempo di oltre 5 secoli. Opera accompagna Oliver alla scoperta di Gutenberg, dei suoi caratteri di stampa.

A special character for a press office with printed features. A leap in time of more than 5 centuries. Opera helps Oliver discovering Gutenberg and printing process in its early days.

Un carácter especial para una oficina de prensa de carácter. Un salto atrás en el tiempo por más de 5 siglos. Opera acompaña a Oliver al descubrimiento de Gutenberg y de la imprenta a sus orígenes.

Un caractère spécial pour un bureau de presse avec caractère. Un saut dans le passé de plus de 5 siècles. Opéra accompagne Olivier à la découverte de Gutenberg et de l'impression à ses débuts.

Особенный характер для особенного пресс-центра. Скачок во времени на более чем в 5 веков. ОПЕРА сопровождает Оливера в открытиях Гутенберга с самого его первых дней.











ATTO VII

Seminario In Corso

Seminar
On The Way

Mentre è in corso un seminario, si può notare come Opera si sia calato nella parte.

La struttura in alluminio pressofuso dai solidi principi sostiene il piano in vetro che rappresenta la verifica delle informazioni. La parete attrezzata protegge le fonti, mentre le pareti vetrate incarnano la trasparenza verso l'esterno con quel pizzico di originalità dei caratteri sulla vetrofania.

While an ongoing seminar, Opera fits at best its place. The hard aluminium structure holds the glass top where information can be verified. The partition wall protects the information while glass partition walls open towards the outside with transparency with a hint of originality using Medieval characters.

Mientras el seminario está en curso, se puede notar cómo Opera ha encajado en el papel. La estructura en aluminio inyectado por sólidos principios soporta el plano en cristal que representa la comprobación de las noticias. La pared equipada representa la protección de las fuentes, mientras las paredes vidriadas encarnan la transparencia hacia el exterior con aquel toque de originalidad dado por los caracteres medievales.

Pendant un séminaire de formation, on peut constater comme Opera est rentrée dans la part. La structure en aluminium créé en moule et tréfilage, des solides principes, soutient le plateau en verre qui sert pour la vérification des informations. L'armoire cloison pour la protection des informations, et les cloisons en verre pour la transparence vers l'extérieur, avec l'originalités des caractères médiévaux.

Пока идет один семинар, можно заметить, как ОПЕРА как бы частично уменьшилась. Литой алюминиевый каркас является основой для стеклянной столешницы и символизирует верификацию информации. Оснащенная перегородка представляет защиту источников, а застекленные стены воплощают прозрачность оригинальность средневековых шрифтов.



himenaeos. Donec rutrum urna eu tellus
per inceptos himenaeos. Integer
eu justo sed accu tempus
voluptat vel at turpis.

Lorem ipsum dolor
adipiscing elit. De
nunc a mattis. Viv
interdum eiusmod

dolor, lacinia ac volutpat s
turpis. Vestibulum ac dolor
luctus. Nullam vulputate s
posuere lectus
lacinia non fuit.
Nullam vulputate
sapien erat stat.

Tempus



Interd



Interd

et in ea re, tunc de viis quibus
lucida, dicitur, ut in
pluribus, ut in
et in ea re, tunc de viis quibus
lucida, dicitur, ut in
pluribus, ut in



ATTO VIII

La Redazione
Al Lavoro

Editorial Staff
In Activity

La redazione è al lavoro, c'è entusiasmo per riportare le notizie per quello che realmente sono, separandole dalle opinioni. E' ampiamente condivisa l'opinione che gli arredi Opera siano il partner più affidabile.

The editing is at work, news want to be reported separately from opinions, focusing on the truth. In this context Opera appears to be the best partner.

La redacción está trabajando, hay entusiasmo por transmitir las noticias por lo que realmente son separándolas de las opiniones. Visión ampliamente compartida que el mobiliario Opera sea el partner más fiable.

La rédaction est au travail, il y a l'enthousiasme pour lancer les news sans rajouter opinions. Opinion partagé, les meubles Opera sont le partner le plus fiable.

Редакция в работе, есть воодушевление донести до людей новости и разные точки зрения. Мнение, широко разделяемое между людьми то, что ОПЕРА – это наиболее надежный партнер.





Maccenas in augue pedentesque, pretium quam et, laculis uena. Donec justo odio, dignitate eu dolor eget, ornare elefend tortor, imper dicitur tenentis nulla teque eu cursum ex utimulidit. Nulla tenenti. Dignam a riefundquo, euismod qui iniam. Sed qui veni. Ut ut posueri sapiam. Donec ante tebeu. Fringilla. Etiam fuisibus enim non urna prosteret. Carstas pestas magna tempus. Aliquam lobus tes tellus ed egestas dapibus. Aliquam condallis est non tetus enimod, eu tempus nibb pulvinar.

Aliquam

Accenas in augue pedentesque, pretium quam et, laculis uena. Donec justo odio, dignitate eu dolor eget, ornare elefend tortor, imper dicitur tenentis nulla teque eu cursum ex utimulidit. Nulla tenenti. Dignam a riefundquo, euismod qui iniam. Sed qui veni. Ut ut posueri sapiam. Donec ante tebeu. Fringilla. Etiam fuisibus enim non urna prosteret. Carstas pestas magna tempus. Aliquam lobus tes tellus ed egestas dapibus. Aliquam condallis est non tetus enimod, eu tempus nibb pulvinar.

Vestibulum

Bidamus pharetra, leo in sagittis malesuada, eros tellus laoreet accen, sed tempor libero ante a nunc. Donec blandit ut ligula fringilla blandit. Nam suscipit ornare ante. Sed velar pulvinar, massa. Scelerisque feugiat

Amman

Aliquam

Vestibulum

Amman

Vestibulum

Amman

Amman

Amman





ATTO IX

Ben Fatto

Well Done

Aspettative ampiamente superate, così Frank si complimenta con Norman che, schermendosi, sostiene che il merito è di Opera e della sua azienda produttrice, ampiamente presente nel mercato internazionale nei contesti più prestigiosi, degna rappresentante di quella scuola che da millenni allietta il mondo intero.

Far more exceeded expectations, Frank congratulates Norman but the credit only goes to Opera and its manufacturer, present in the most prestigious levels on the international market, worthily representing a reality enriching the world for thousands of years.

Expectativas ampliamente superadas, así Frank felicita a Norman, el cual, esquivando los elogios, argumenta que el mérito es de Opera y de la empresa que la produce, presente en el mercado internacional en los contextos más prestigiosos, digna representante de aquella escuela que por milenios alegra al mundo entero.

Attentes largement atteintes, de telle manière Franck se félicite avec Norman, que avec modestie déclare que le mérite est à Opera et à son fabricant, présent dans le marché international et dans ses lieux les plus prestigieux, comme représentât de l'école qui réjouit tout le monde depuis des milliers d'années.

Ожидания превзойдены так, что Франк получает комплименты от Норманна, и, как бы отражая лучи восхищения, говорит о непревзойденной заслуге ОПЕРЫ и фабрике, преподносит ее на международном рынке в наиболее престижных контекстах, как достойную наследницу той школы, которая радует целый мир уже сотни лет.











THE END



“LA CONCLUSIONE DELL’OPERA
NON SCRIVERLA NEL SOLITO AMBIENTE DI LAVORO.
NON NE TROVERESTI IL CORAGGIO”.

Walter Benjamin

“Don’t end up the work in the usual working environment.
You wouldn’t be courageous enough”.

“No escribas la conclusión de la obra en tu despacho habitual.
En el no encontrarás valor para hacerlo”.

“La conclusion de l’oeuvre ne l’écrire pas dans la place de travail habituelle.
Tu n’en trouveras pas le courage”.

“Завершить дело – не писать ее в обычной обстановке работы.
Не найдете мужества”.

OPERA

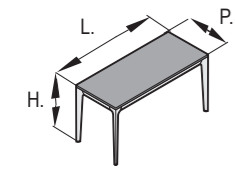
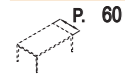

P. 60 x H.76,5
 * L. 280
 L. 210
 L. 140

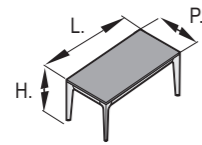

P. 60 x H.45
 L. 120
 L. 60

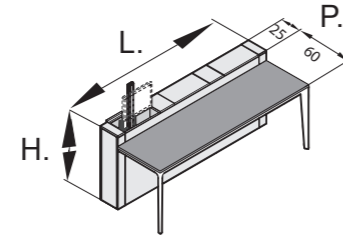

P. 85 x H. 76,5
 * L. 280
 L. 210
 L. 140

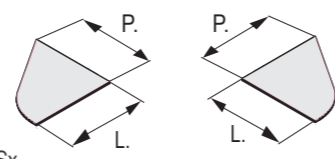

Sx Right
 Droit
 Derecho
 Правый
 L. 85 x P. 85 x H. 1,8
 Dx Left
 Izquierda
 Gauche
 Левый

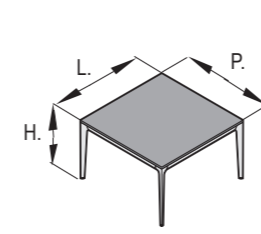

L. 120 x P. 120 x H.76,5

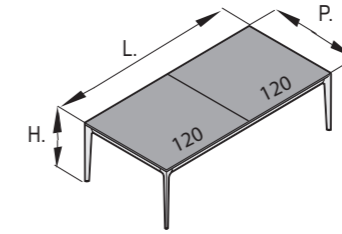

L. 240 x P. 120 x H.76,5

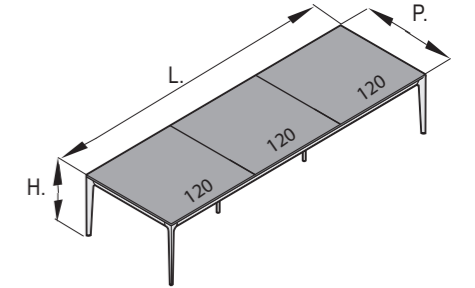

L. 360 x P. 120 x H.76,5

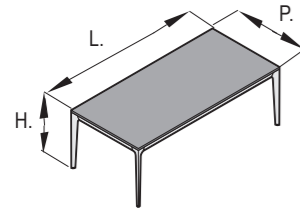

P. 100 x H.76,5
 * L. 250
 L. 210
 L. 180

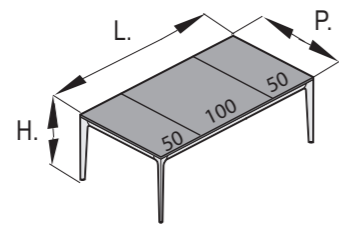

L. 200 x P. 100 x H.76,5

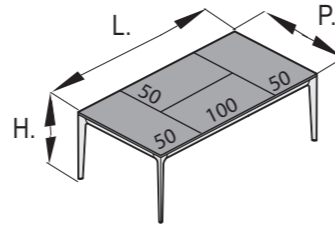

L. 200 x P. 100 x H.76,5

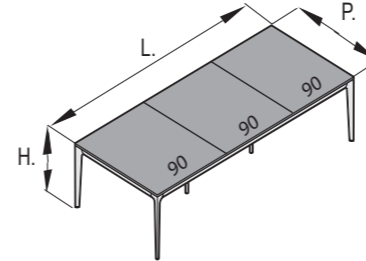

L. 270 x P. 120 x H.76,5

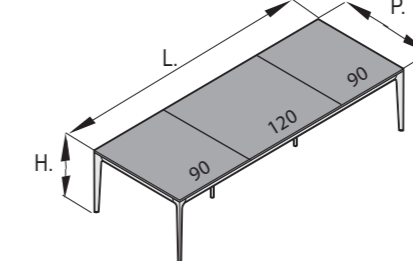

L. 300 x P. 120 x H.76,5

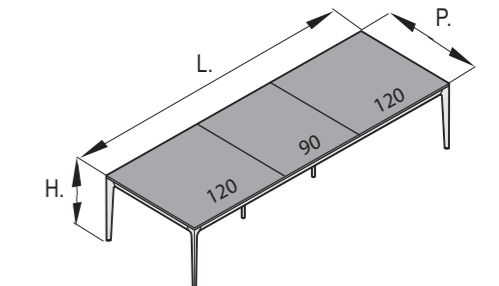

L. 330 x P. 120 x H.76,5

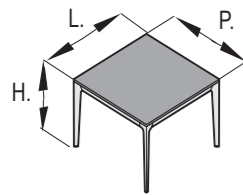

L. 100 x P. 100 x H.76,5

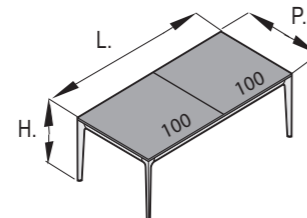

L. 200 x P. 100 x H.76,5

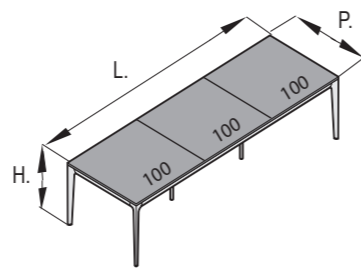

L. 300 x P. 100 x H.76,5

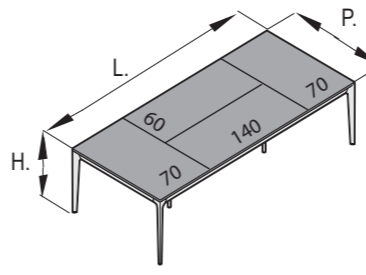

L. 280 x P. 120 x H.76,5

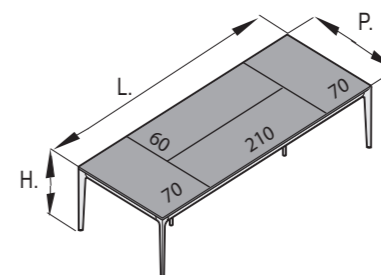

L. 350 x P. 120 x H.76,5

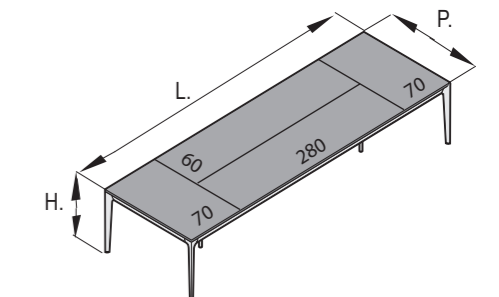

* L. 420 x P. 120 x H.76,5

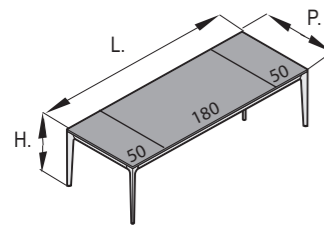

L. 280 x P. 100 x H.76,5

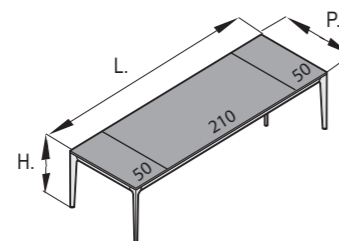

L. 310 x P. 100 x H.76,5

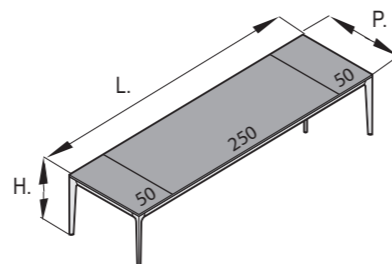

* L. 350 x P. 100 x H.76,5

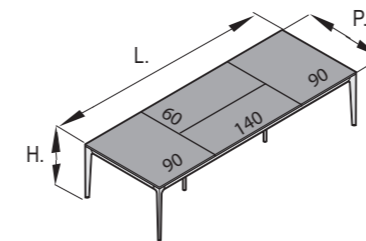

L. 320 x P. 120 x H.76,5

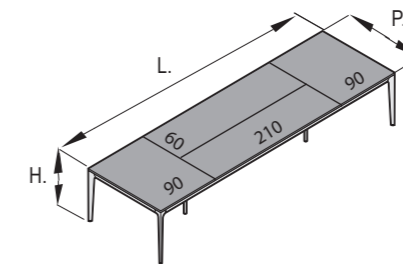

L. 390 x P. 120 x H.76,5

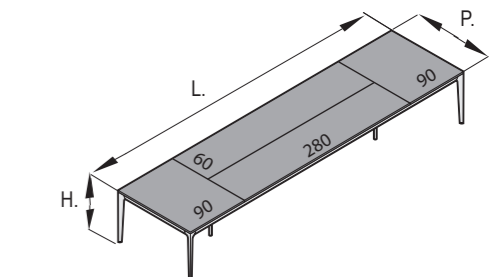

* L. 460 x P. 120 x H.76,5

L. Lunghezza - Length - Anchura - Longueur - Длина
 P. Profondità - Depth - Profundidad - Profondeur - Глубина
 H. Altezza - Height - Altura - Hauteur - Высота

* : ✕ Vetro non disponibile - Glass not available - Vidrio no disponible - Verre pas disponible - Стекло не предусмотрено

L. Lunghezza - Length - Anchura - Longueur - Длина
 P. Profondità - Depth - Profundidad - Profondeur - Глубина
 H. Altezza - Height - Altura - Hauteur - Высота

* : ✕ Vetro non disponibile - Glass not available - Vidrio no disponible - Verre pas disponible - Стекло не предусмотрено

OPERA

P. 120

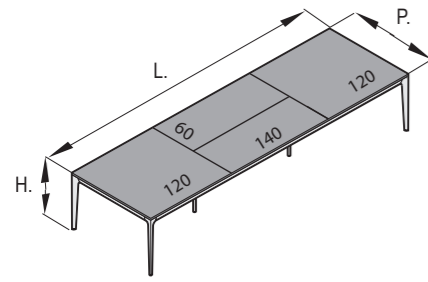

L. 380 x P. 120 x H.76,5

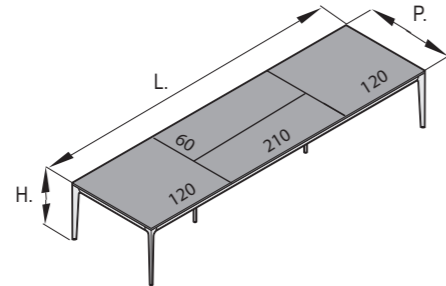

L. 450 x P. 120 x H.76,5

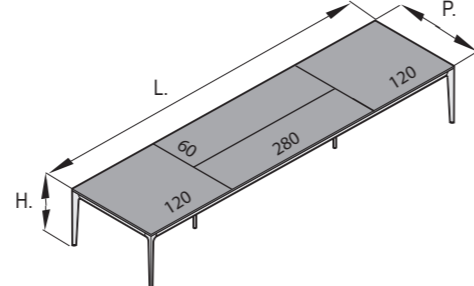

L. 520 x P. 120 x H.76,5

P. 140

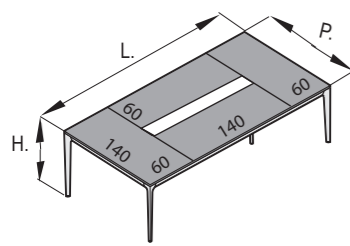

L. 260 x P. 140 x H.76,5

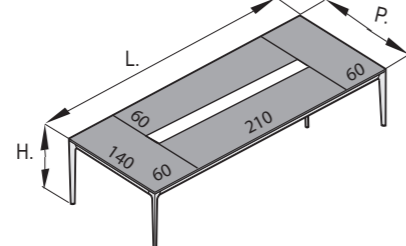

L. 330 x P. 140 x H.76,5

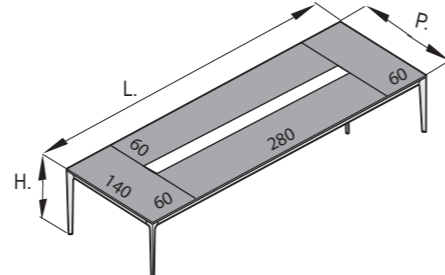

L. 400 x P. 140 x H.76,5

P. 160

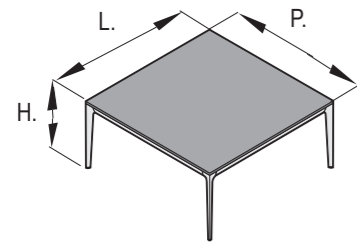

L. 160 x P. 160 x H.76,5

P. 200

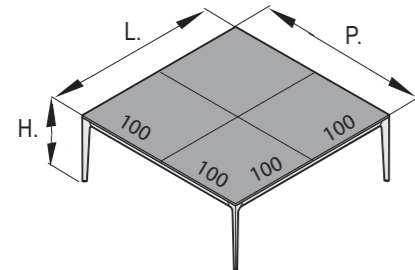

L. 200 x P. 200 x H.76,5

P. 240

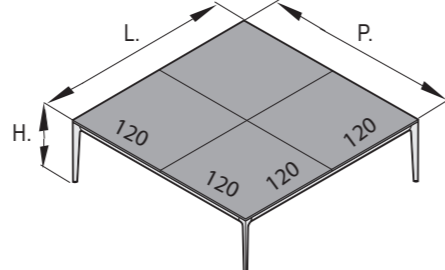

L. 240 x P. 240 x H.76,5

L. Lunghezza - Length - Anchura - Longueur - Длина
 P. Profondità - Depth - Profundidad - Profondeur - Глубина
 H. Altezza - Height - Altura - Hauteur - Высота

: Vetro non disponibile - Glass not available - Vidrio no disponible - Verre pas disponible - Стекло не предусмотрено

Sottomano attrezzato
 Equipped Desk Pad
 Sous Main Equipe
 Рабочий стол колodки оборудованы

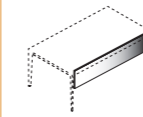
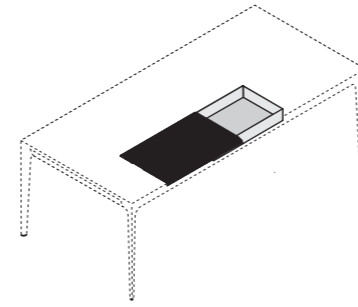

Cassettiere in metallo su ruote
 Metal pedestals on castors
 Cajoneras en metal sobre ruedas
 Caisson mélaminés mobiles
 Металлическая кассетница на колёсиках

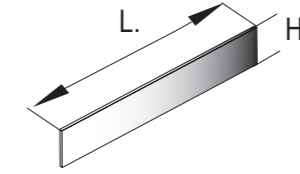

L. 156 x H. 35 x 2



L. 42,5 x P. 53 x H.58

Librerie
 Bookcases
 Librerias
 Modules bibliothèque
 Шкафы

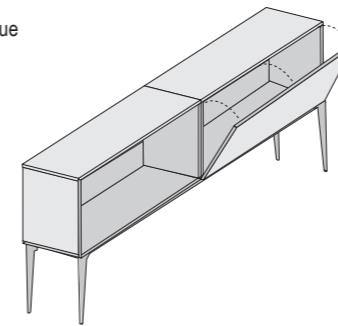

L. 180 x P. 37 x H.85

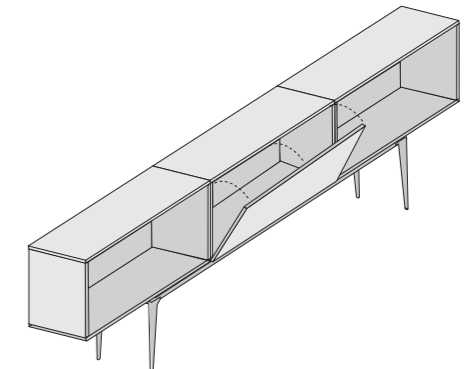

L. 270 x P. 37 x H.85

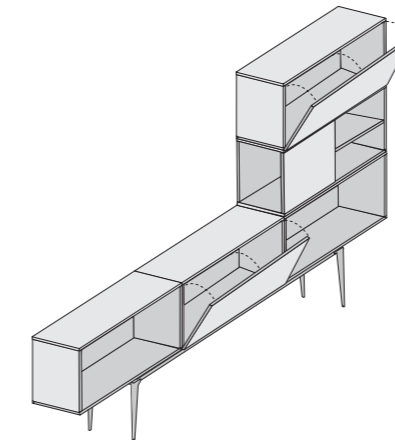

L. 270 x P. 37 x H.85 - 165

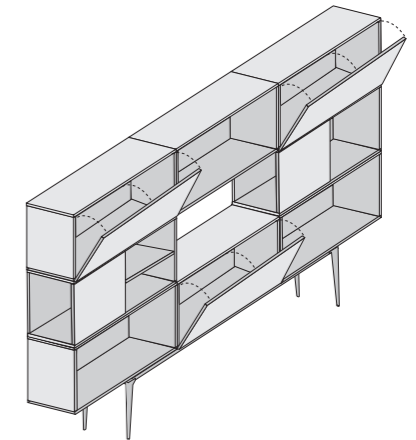



L. 270 x P. 37 x H.165



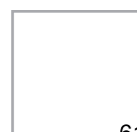
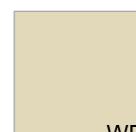

L. Lunghezza - Length - Anchura - Longueur - Длина
 P. Profondità - Depth - Profundidad - Profondeur - Глубина
 H. Altezza - Height - Altura - Hauteur - Высота

OPERA









COLORI LAMINATO - LAMINATED COLORS - COLORES DE LAMINADO - COLORIS DE STRATIFIE' - ЦВЕ ПРОКАТАННЫЕ



FINITURA LUCIDA - GLOSSY FINISHING - ACABADO BRILLO - FINITION BRILLANTE - ГЛЯНЦЕВАЯ ОТДЕЛКА

 61 Bianco White Blanco Blanc Белый	 WD Sabbia Sand Arena Sable Песочный	 BD Lavanda Lavender Lavanda Lavande Лаванда	 VF Verde acido Acid green Verde ácido Vert acide Зеленое яблоко	 UA Arancio Orange Naranja Orange Оранжевый	 HA Ciclamino Cyclamen Cidamen Cyclamen Розово-лиловый	 RD Rosso devil Devil red Rojo devil Rouge devil Демонический красный	 RE Rosso oriente Orient red Rojo oriente Rouge oriental Красный вос
---	--	--	--	---	---	---	--

 BC OUT OF PRODUCTION Blu spazio Space blue Azul espacio Bleu ciel Синий космос	 BB Blu manto Mantle blue Azul manto Bleu manteau синий покров	 GC Grigio antracite Charcoal grey Gris antracita Gris anthracite Серый антрацит	 BL Nero Black Negro Noir Черный
---	--	--	--

FINITURA OPACA - MATT FINISHING - AVACADO MATE - FINITION MATE - МАТОВАЯ ОТДЕЛКА

 05 Bianco White Blanco Blanc Белый	 W4 Sabbia Sand Arena Sable Песочный	 B7 Lavanda Lavender Lavanda Lavande Лаванда	 V6 Verde acido Acid green Verde ácido Vert acide Зеленое яблок	 U5 Arancio Orange Naranja Orange Оранжевый	 H2 Ciclamino Cyclamen Cidamen Cyclamen Розово-лиловый	 R5 Rosso devil Devil red Rojo devil Rouge devil Демонический красный	 R6 Rosso oriente Orient red Rojo oriente Rouge oriental Красный вос точный
---	--	--	---	---	---	---	---





 B6 OUT OF PRODUCTION Blu spazio Space blue Azul espacio Bleu ciel Синий космос	 B5 Blu manto Mantle blue Azul manto Bleu manteau синий покров красный	 G3 Grigio antracite Charcoal grey Gris antracita Gris anthracite Серый антрацит	 04 Nero Black Negro Noir Черный	 VM finitura metallizzata metallic finish acabado metálico finition métallique металлической отделкой Visone metallizzato Mink metallic Mink métallique Visón metalizado Норка металллик	 WU finitura laminato leather leather laminate finish finition stratifié cuir acabado laminado cuero отделка ламинат кожи Bianco luna Moon white Blanc lune Blanco luna Белая луна
---	--	--	--	--	---

LEGNO - WOOD - MADERA - DECOR BOIS - ДЕРЕВО

 65 Bianco White Blanco Blanc Белый	 91 OUT OF PRODUCTION finitura pasca peach finishing textura melocotón finition pêche отделка персик Rovere chiaro Light oak Roble claro Rouvre clair Светлый дуб	 63 Noce barocco Barocco walnut Nogal barocco Noyer baroque Орех бароко	 51 Ciliegio americano American cherry Cerezo rojo Cerisier américain Американская вишня	 70 Larice cenere Larch wood ash Alerce ceniza Mélèze cendre Пепельная лиственница	 56 Larice montano Montano larch Alerce montano Mélèze montano Лиственница монтано	 41 Zebano Oliva Zebrano olive Zebrano aceito Zebrano olive Зебран
---	--	---	--	---	--	--

 83 OUT OF PRODUCTION Ebano makassar Makassar ebony Ebano makassar Ebène makassar Эбеновый макассар	 80 Out line Out line Out line Исходящая линия	 60 finitura pasca peach finishing textura melocotón finition pêche отделка персик Rovere moro Black oak Roble oscuro Rouvre brun Мореный дуб	 WE Wengè loft Wengè loft Wengué loft Wenge loft Венге лофт
---	---	--	---

COLORI LAMINATO FENIX - FENIX LAMINATED COLORS - COLORES DE LAMINADO FENIX - COLORIS DE STRATIFIE' FENIX - ЦВЕ РОКАТАННЫЕ FENIX

 BW Bianco Alaska Alaska white Blanco Alaska Blanc Alaska Белый Аляска	 CO Castoro Ottawa Ottawa beaver Castor Ottawa Castor Ottawa Бивер Оттава	 CW Grigio Londra London grey Gris Londre Gray Londres Серый Лондон	 DW Nero Ingo Ingo black Negro Ingo Noir Ingo Черный Инго
--	---	---	---

Finitura metallizzata
metallic finish
acabado metálico
finition métallique
металлической отделкой





 EN OUT OF PRODUCTION Zinco Doha Doha zinc Zinc Doha Zinc Doha Цинк в Дохе	 TC OUT OF PRODUCTION Bronzo Doha Doha bronze Bronze Doha Bronze Doha Бронзовый Доха	 E0 OUT OF PRODUCTION Piombo Doha Doha lead Plomo Doha Plomb Doha Свинец Доха
--	--	---

COLORI MELAMINICO - MELAMINE COLORS - COLORES DE MELAMINA - COLORIS DE MELAMINE - ЦВЕ Меламин

 E5 Tranchè olmo Tafira Tafira elm tranchè Tranchè olmo Tafira Tranchè olmo Tafira Транше ольха тафиро	 T8 Tranchè rovere bruges Bruges oak tranchè Tranchè roble Bruges Tranchè chêne Bruges Транше дуб Брюгге	 E4 Tranchè olmo Jerez Jerez elm tranchè Tranchè olmo Jerez Tranchè olmo Jerez Транше ольха Херес	 E3 Tranchè frassino grigio Grey ash tranchè Tranchè fresno gris Tranchè frêne gris Транше серый ясен	 GS Grigio silicio Silicon grey Gris silicio Gris silicium Серый кремния RAL7032	 GQ Grigio quarzo Quartz grey Gris cuarzo Gris quartz Серый кварц RAL7039
--	--	---	---	--	---

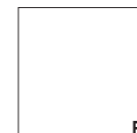
COLORI VETRO - GLASS COLORS - COLORES DE VIDRIO - COLORIS DE VERRE - Цветное стекло



Vetro verniciato - Varnished glass - Vidrio pintado - Verre verni - Окрашенное стекло

 BI Bianco White Blanco Blanc Белый	 GS Grigio silicio Silicon grey Gris silicio Gris silicium Серый кремния RAL7032	 GQ Grigio quarzo Quartz grey Gris cuarzo Gris quartz Серый кварц RAL7039	 RO Rosso Red Rojo Rouge Красный	 NE Nero Black Negro Noir Черный
---	--	---	--	--

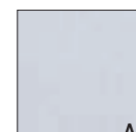

STRUTTURA METALLO - Metal structure - Estructura en metal - Structure métal - Металлическая структура

MODESTY PANEL METALLO - Steel modesty panels - Faldón metálico - Volile de fond métallique - ПАНЕЛЬ «MODESTY» МЕТАЛЛ

CASSETTIERE METALLICHE - Steel chest of drawers - Cajoneras metálicas - Caissons métallique - КАССЕТИЦА МЕТАЛЛ

 BI Bianco White Blanco Blanc Белый	 AL Alluminio Aluminum Aluminio Aluminium Алюминий	 NE Nero Black Negro Noir Черный
---	--	--

CASSA LIBRERIA MELAMMINICO - MELAMINE BOOKCASE STRUCTURE - CARCASA LIBRERÍA MELAMINA - CORPS ARMOIRE MELAMINEE - КАРКАС КНИЖНОГО ШКАФА

 GS Grigio silicio Silicon grey Gris silicio Gris silicium Серый кремния RAL7032	 GQ Grigio quarzo Quartz grey Gris cuarzo Gris quartz Серый кварц RAL7039
--	---

Art Director: Riccardo Vicenzetti with Newform Ufficio Technical Dept.
Styling: Lara Santin
Image: Nerokubo
Fotolito e stampa: Sincromia



L'effettiva disponibilità di quanto a catalogo dev'essere effettivamente verificata al momento dell'ordine. A causa di naturali limiti tecnici di riproduzione e stampa, il colore dei modelli a catalogo è puramente indicativo e non può costituire motivo di rivalsa. Aran World S.r.l.U., assecondando la propria vocazione ecologista, ha adottato il font Calibri al fine di contribuire ulteriormente a salvaguardare il nostro pianeta grazie al ridotto consumo di toner e carta.

The company actively pursues an ambitious continuous improvement policy and it reserves the right to make at any time and without prior notice the changes in the product as it deems useful and necessary. The actual availability of the items shown in the catalogue must be verified at the time of the order. Due to technical limitations in natural reproduction and printing, the colour of the models in the catalogue are purely indicative and cannot be a reason for recourse. Aran World S.r.l.U., favoring its ecological vocation, has adopted the Calibri font in order to further contribute to safeguard our planet in reducing consumption of paper and toner thanks to this device.

Aran World S.r.l.U., persiguiendo una política destinada a una constante mejora, se reserva el derecho de aportar, en cualquier momento y sin preaviso, las modificaciones a los productos que considerará útiles y necesarias. La efectiva disponibilidad de lo indicado en el presente catálogo debe efectivamente comprobarse al momento de realizar el pedido. Debido a naturales límites técnicos de reproducción e impresión, el color de los modelos del catálogo es puramente indicativo y no puede constituir un motivo de indemnización. Aran World S.r.l.U., siguiendo su propia vocación ecológica, ha adoptado el font Calibri con el fin de ayudar ulteriormente a proteger nuestro planeta, gracias a la reducción del consumo de tóner y de papel.

Aran World S.r.l.U. pour poursuivre une politique vers la constant amélioration, se réserve le droit d'apporter, n'importe quand et sans préavis, les modifications retenues utiles et nécessaires. L'effective disponibilité des articles du catalogue sera objet de vérification lors de la commande. A' cause des limites techniques de reproduction et impression, les coloris de la gamme et du catalogues sont indicatives et ne peuvent pas faire objet de réclamation. Aran World S.r.l.U., dans la cible de respecter sa vocation écologiste, a utilisé le font Calibri pour contribuer à sauvegarder l'environnement de la planète grâce à la réduite consommation de toner et papier que cette choix amène.

Aran World S.r.l.U., следуя политике постоянного обновления оставляет за собой право привносить в любой момент и без предупреждения любые изменения, какие посчитает нужным и полезным. Наличие решений, приведенных в каталоге, должна быть верифицирована в момент заказа. По причине технологических ограничений в передаче цвета на бумаге, цвет отделки, приведенной в каталоге, является ориентировочным и не может быть предметом претензий. Aran World S.r.l.U. отвечая экологическому призыву, использует шрифт Calibri для уменьшения расходов тонера и бумаги, что способствует сохранению нашей планеты.

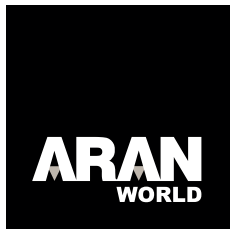

Aran World S.r.l. Unipersonale

Zona Industriale, Frazione Casoli - 64032 Atri (TE) Italy

Italia: Tel. +39 085 871151 - Fax +39 085 87115403

Export: Tel. +39 085 870971 - Fax +39 085 87115405

newform.ufficio@aran.it www.aran.it

0000000916



AW00001072448

