

**uffix**

**uffix**

ESSENCE

Essence



Essence

**uffix**

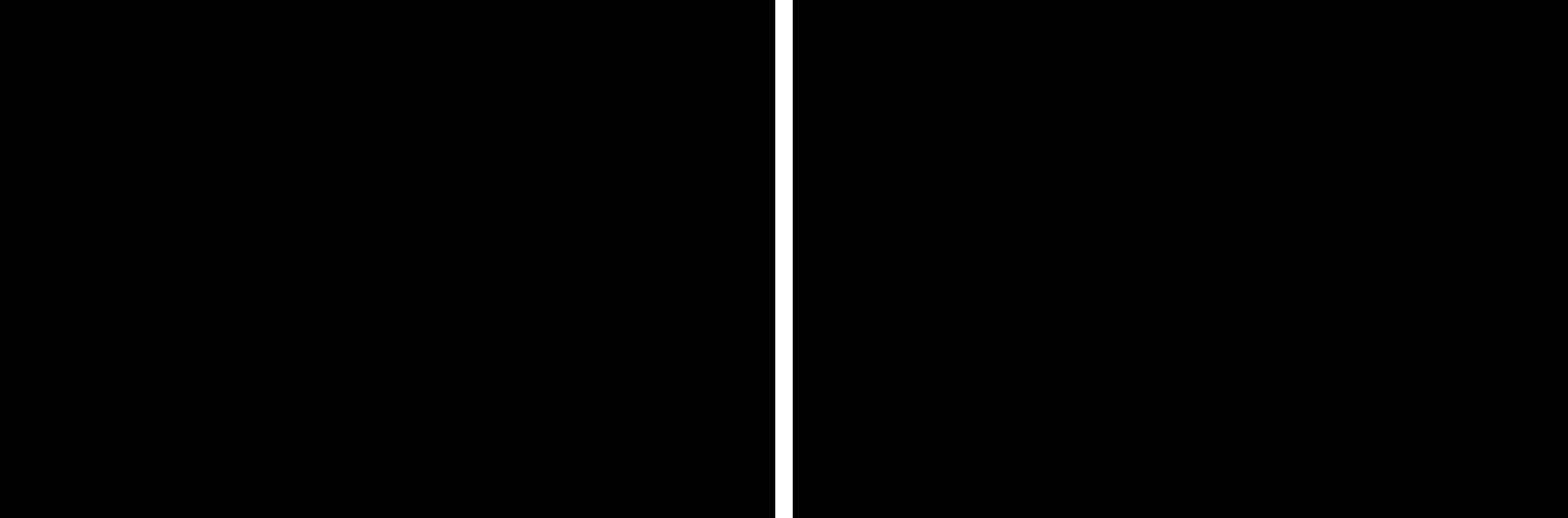



design **DRIUSSO ASSOCIATI** | **ARCHITECTS**



Arch. Franco Driusso

## ESSENCE

ESSENCE è la nuova collezione di Uffix dedicata ad un ambiente direzionale elegante e razionale. Un concept dal design rigoroso ed essenziale, che si inserisce con armonia ed equilibrio nello spazio. E' l'incontro tra contenuti e valori estetici differenti che esprime un'idea di "living-office" coerente con le moderne tendenze dell'abitare.

ESSENCE is Uffix new executive collection, both elegant and proportioned. This concept has an essential and rigorous design which inserts itself into the space with harmony and balance. It represents the meeting between contents and different aesthetical values and expresses the trendy ideas of "living office", typical of the modern domestic environments.

Essence est la nouvelle collection de la Maison Uffix, dédiée à une ambiance directionnelle élégante et rationnelle. Un concept de design rigoureux et épuré, ce qui lui permet de s'intégrer de manière harmonieuse et équilibrée dans l'espace. C'est la rencontre entre des contenus et des différentes valeurs esthétiques qui exprime une idée de "living office" cohérente avec les tendances modernes de l'ameublement.

Essence es la nueva colección direccional de Uffix dedicada a un ambiente elegante y equilibrado. Es un concepto con un diseño riguroso y esencial que se introduce con armonía en el espacio. Representa el encuentro entre contenidos y diferentes valores estéticos expresando la idea de "oficina-hogar", en línea con las tendencias modernas de las viviendas.

Essence - это новая коллекция от Uffix, которая отличается своей элегантностью и практичностью и отлично подойдет для директорской зоны. Это концепция, которая базируется на строгом и лаконичном дизайне, и к тому же гармонично вписывается в офисном пространстве. Это баланс между сущностью и различными эстетическими нормами, выражающими идею "living-office" и современными тенденциями оформления пространства.







## TACTILE MELAMINE

Finiture materiche, dai colori caldi e naturali. È l'effetto tattile e decorativo del nuovo melaminico "Tactile" che evoca il feeling e la naturalezza del legno. La superficie diventa protagonista con sobrietà ed eleganza.

Textured finishes with natural warm shades. This is the effect of the "Tactile" new melamine, which recalls real wood veneer naturalness and feeling. Elegant and refined surfaces become the most important feature.

Finitions matières aux couleurs chaudes et naturelles. C'est l'effet tactile et visuel du nouvel mélaminé décoratif "Tactile", qui rappelle à la vue et au toucher la texture du bois naturel. La surface devient importante dans sa simplicité et élégance.

Acabados táctiles con tonos cálidos y naturales. El nuevo melamínico "Tactile" recuerda la sensación y la naturaleza de la madera. Las superficies se convierten en protagonistas sobrias y elegantes.

Текстурные отделки в теплых и природных оттенках. Это тактильный и визуальный эффект нового меламинового покрытия "Tactile", имитирующего на ощупь натуральное дерево. Поверхность становится главным элементом пространства, со всей своей простотой и элегантностью.



HONEY



DESERT



EARTH



MOKA



TAN









EARTH





EARTH



EARTH

# Essence

# Essence





DESERT



MOKA



HONEY





Essence  
Essence





Con ESSENCE l'ambiente ufficio esplora le atmosfere del living contemporaneo. Lo spazio diventa più intimo e familiare, accogliente. L'originale collezione di complementi d'arredo estende la personalizzazione con divani, poltrone e tavolini dedicati.

ESSENCE joins office environment with domestic contemporary atmospheres. Space becomes more intimate, familiar and welcoming. Customisation can be increased by use of an original range of matching sofas, armchairs and coffee tables.

La gamme ESSENCE donne à l'ambiance bureau une atmosphère living contemporaine. L'espace devient plus personnel, confortable et accueillant. La collection originale de mobiliers permet de personnaliser ultérieurement l'espace grâce à des canapés, des fauteuils et à des petites tables assorties.

ESSENCE une el ambiente de oficina con las atmósferas del hogar contemporáneo. El espacio se vuelve cada vez más íntimo y familiar, acogedor. La original colección de complementos permite una mayor personalización con sofás, sillones y mesitas de café.

Благодаря ESSENCE офисная среда приобретает атмосферу современной living-зоны. Офисное пространство становится более личным, знакомым и уютным. Оригинальная коллекция мебели идеально дополняется благодаря диванам, креслам и сочетающимся с ними столикам.







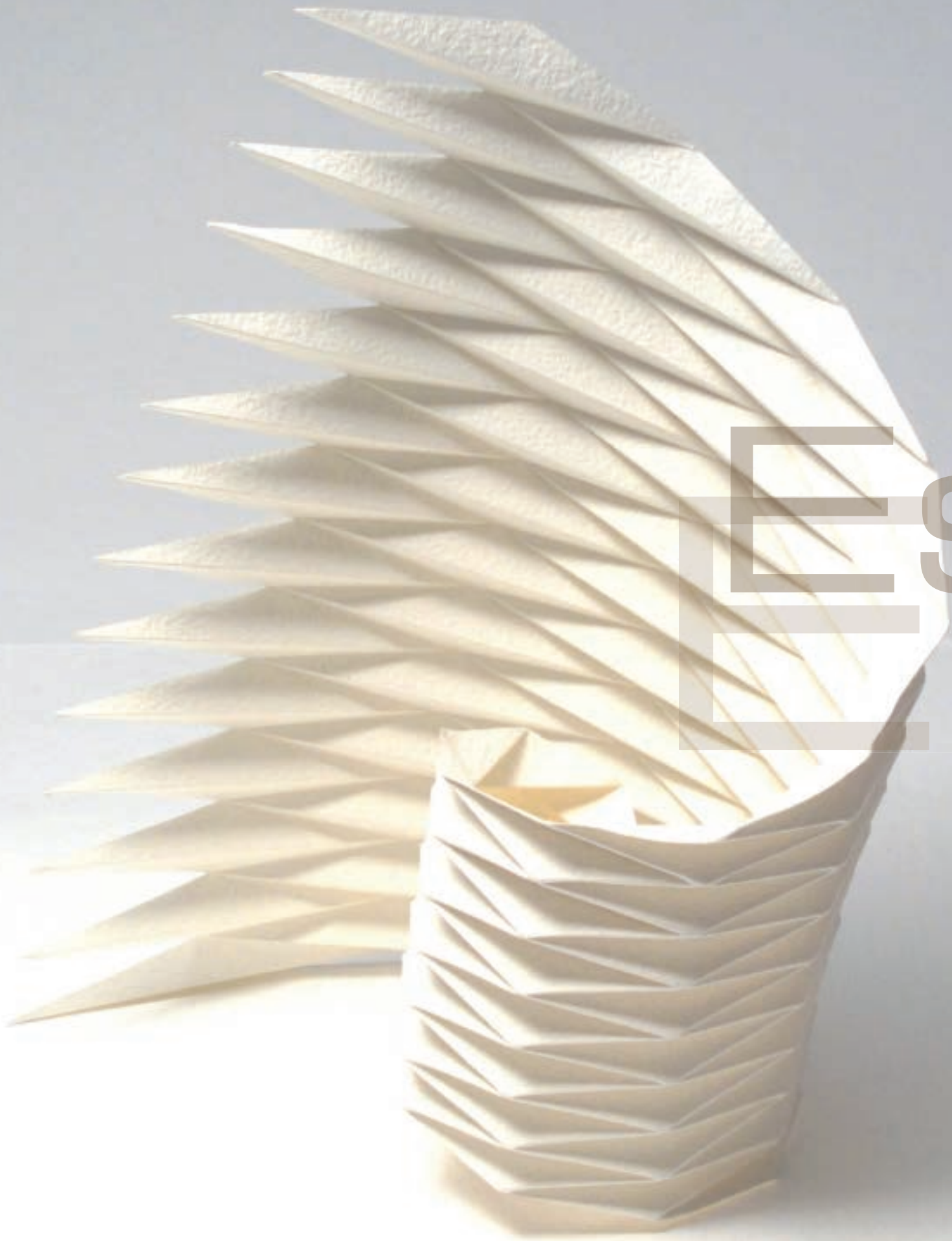

# Essence essence



EARTH





Ergonomia e flessibilità sono prerogative importanti per favorire lo scambio e la condivisione delle informazioni. Il design essenziale dei tavoli Essence interpreta con razionalità ed efficacia l'organizzazione dello spazio rendendo fluido il confronto collaborativo.

Ergonomics and flexibility are two essential features which make information easier to share. The essential design of Essence meeting tables allows more fluid and collaborative exchanges through a better organised space.

Ergonomie et flexibilité sont des facteurs importants qui permettent de faciliter l'échange et le partage d'informations. Le design épuré des tables Essence permet une organisation rationnelle et efficace de l'espace et favorise une collaboration optimale.

Ergonomía y flexibilidad son necesarias para fomentar la conversión de las informaciones. El diseño tan esencial de las mesas Essence interpreta con elegancia y eficacia la organización del espacio para que el diálogo sea fluido y cooperativo.

Эргономичность и гибкость - это важные факторы, которые создают нужную среду для легкого обмена информацией. Лаконичный дизайн столов Essence придаёт офисному пространству максимальную функциональность и эффективность и способствует дружеской атмосфере в процессе деловой беседы.





DESERT



EARTH

# Essence

## Technical Details

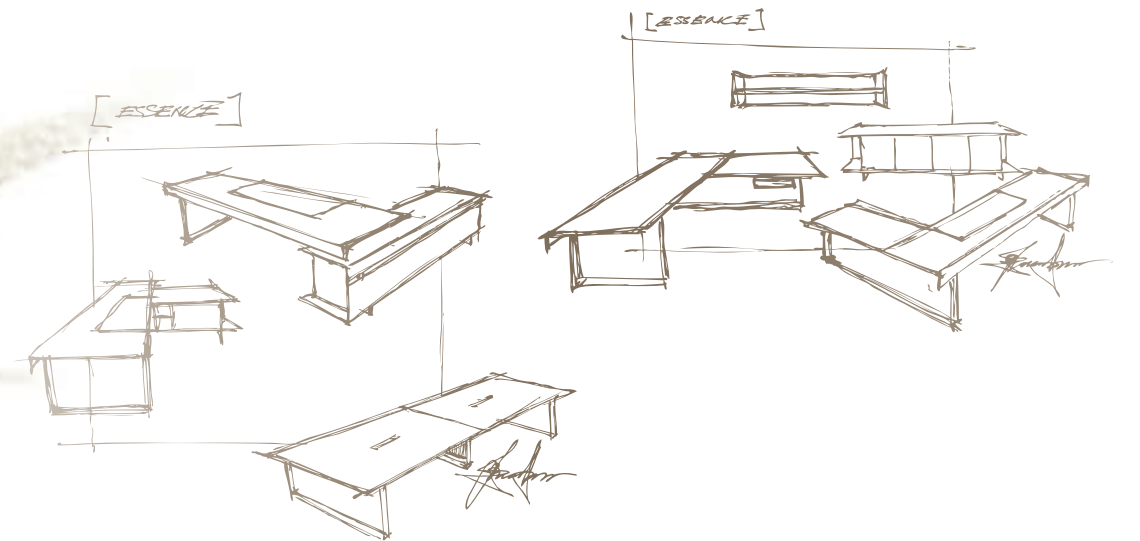

ARMADI , STORAGE UNITS , ARMOIRES , ARMARIOS , ШКАФЫ



TAVOLI COLLOQUIO , SMALL MEETING TABLES , TABLES DE CONVIVIALITÉ , MESAS PEQUEÑAS , СТОЛЫ ДЛЯ ЗАСЕДАНИЙ



TAVOLO BASSO , COFFEE TABLE , TABLE BASSE , MESITA DE CAFÉ , НИЗКИЙ СТОЛИК



MOBILE SERVIZIO , SUPPORTING CREDENZA , MEUBLE DE RETOUR , MUEBLE DE SERVICIO , СЕРВИСНАЯ ТУМБА



CREDENZA , CREDENZA , CRÉDENCE , APARADOR , КОМОД

CONSOLLE , CONSOLE TABLE , CONSOLE , CONSOLA , КОНСОЛЬ



FULL OPTIONAL

CASSETTIERE , PEDESTALS , CAISSONS , BUCS , ТУМБОЧКИ

PORTA CPU , CPU HOLDER , SUPPORT PC , PORTA CPU  
 ПОДСТАВКА ПОД СИСТЕМНЫЙ БЛОК



TOP ACCESS CABLE LID , ACCES ELECTRIFICATION , TOP ACCESS  
 ЛЮК "TOP ACCESS"

TOP ACCESS CON PRESE , CABLE LID WITH SOCKETS , ACCES  
 ELECTRIFICATION AVEC PRISES , ELECTRIFICACIÓN CON ENCHUFES ,  
 ЛЮК "TOP ACCESS" С БЛОКОМ РОЗЕТОК

SCRIVANIA , DESK , BUREAU , ESCRITORIO , ПИСЬМЕННЫЙ СТОЛ

SCRIVANIA , DESK , BUREAU , ESCRITORIO , ПИСЬМЕННЫЙ СТОЛ



TAVOLO , MEETING TABLE , TABLE , MESA DE JUNTAS , СТОЛ

TAVOLO , MEETING TABLE , TABLE , MESA DE JUNTAS , СТОЛ



FINITURE MELAMINICO , MELAMINE FINISHES , FINITIONS MELAMINE , ACABADOS DE MELAMINA , ОТДЕЛКИ МЕЛАМИНОВЫЕ



Honey M214



Desert M213



Earth M205



Moka M215

STRUTTURE CONTENITORI , CREDENZA STRUCTURE  
STRUCTURES CONTENEURS , ESTRUCTURA CONTENEDORES  
СТРУКТУРЫ КОНТЕЙНЕРОВ



Tan M110

STRUTTURE ARMADI , STORAGE STRUCTURES  
STRUCTURES ARMOIRES , ESTRUCTURAS ARMARIOS  
КОРПУСА ШКАФОВ



Silver M106

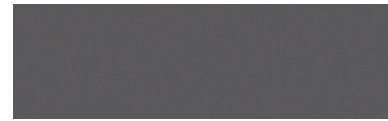

Anthracite M108

STRUTTURE SCRIVANIA ED ARTICOLI IN METALLO , DESK STRUCTURES AND METAL ITEMS ,  
STRUCTURES BUREAU ET ÉLÉMENTS EN MÉTAL , ESTRUCTURAS ESCRITORIO Y  
ELEMENTOS METÁLICOS , СТРУКТУРЫ ПИСЬМЕННОГО СТОЛА И МЕТАЛЛИЧЕСКИЕ ЭЛЕМЕНТЫ



\* Tan F114

ANTE VETRO , GLASS DOORS , PORTES VERRE  
PUERTAS VIDRIO , СТЕКЛЯННЫЕ СТВОРКИ

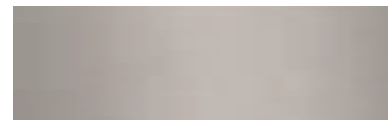

Stopsol

\* Structure sottopiano Anthracite , Anthracite structures under the top , Structures sous plateau anthracite , Estructuras antracita bajo tapa , СТРУКТУРЫ ПОД СТОЛЕШНИЦЕЙ В ЦВЕТЕ "АНТРАЦИТ"

PASSAMANO PELLE , HIDE INLAY , SOUS-MAIN EN CUIR  
VADE DE CUERO , КОЖАНЫЙ БЮВАР



Black P201



Tan P205

TOP ACCESS , CABLE LID , ACCES ELECTRIFICATION  
TOP ACCESS , ЛЮК "TOP ACCESS"



Silver

LAMPADE , LAMPS , LAMPES , LÁMPARAS , ЛАМПЫ

STRUTTURA , STRUCTURE  
STRUCTURE , ESTRUCTURA  
СТРУКТУРА

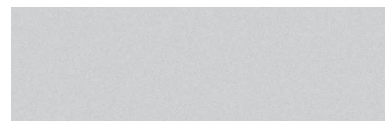

Silver

DIFFUSORE , LAMP SHADE  
DIFFUSEUR , DIFUSOR , РАСПРЕДЕЛИТЕЛЬ

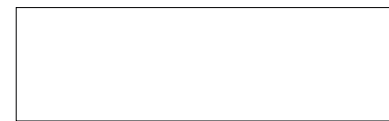

White

DIVANI E TAVOLINI , SOFAS AND COFFEE TABLES , CANAPES ET PETITES TABLES , SOFÁS Y MESITAS DE CAFÉ , ДИВАНЫ И СТОЛИКИ

TESSUTO , FABRIC , TISSU , TELA , ТКАНЬ

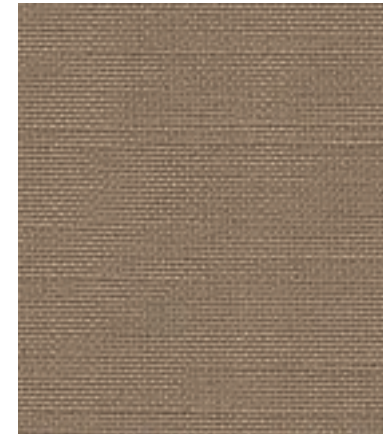

T105



T101

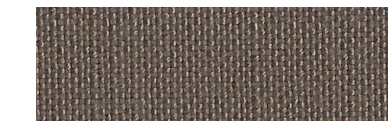

T106

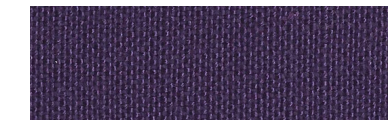

T108

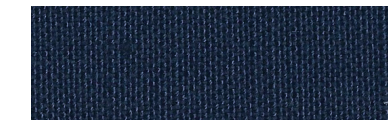

T109



T107



T104

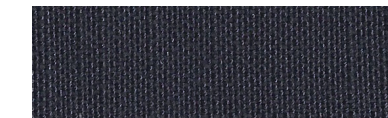

T103

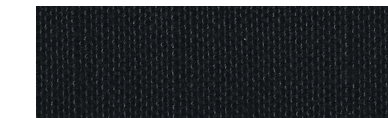

T102

SIMIL-PELLE , LEATHERETTE , SIMILI-CUIR , PIEL SINTÉTICA , ИСКУССТВЕННАЯ КОЖА

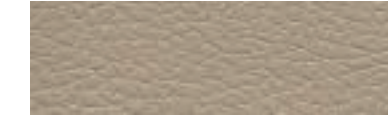

P501



P502



P503



P504



P505



P506



P509



P508



P507

PELLE , LEATHER , CUIR , PIEL , КОЖА

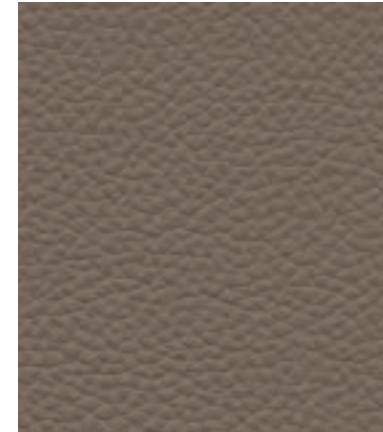

P305



P306



P307



P308



P309



P310

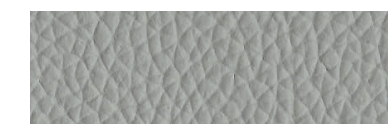

P312

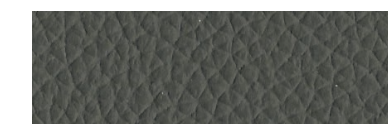

P311

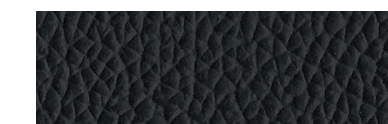

P314

SCRIVANIE , DESKS , BUREAUX , ESCRITORIOS , ПИСЬМЕННЫЕ СТОЛЫ

<p>cm. 180 / 200 / 220 L 90 P 74 H in. 70,9 / 78,7 / 86,6 W 35,4 D 29,1 H</p> <p>AES-15106 AES-15107 AES-15109</p> <p>AES-15906 AES-15907 AES-15909</p>	<p>cm. 180 / 200 / 220 L 178 P 74 H in. 70,9 / 78,7 / 86,6 W 70,1 D 29,1 H</p> <p>AES-17406 AES-17407 AES-17409</p> <p>AES-10406 AES-10407 AES-10409</p>	<p>cm. 88 L 56 P 74 H in. 34,6 W 22 D 29,1 H</p> <p>AES-50301</p>
---	--	---

SCRIVANIE CON CARTER , DESKS WITH CABLE RISER , BUREAUX AVEC PASSAGE DE CABLES VERTICAL (CARTER)  
ESCRITORIOS CON PEDESTAL ELECTRIFICABLE , ПИСЬМЕННЫЕ СТОЛЫ С ВЕРТИКАЛЬНОЙ ПРОВОДКОЙ КАБЕЛЯ ( С КАРТЕРОМ)

<p>cm. 180 / 200 / 220 L 90 P 74 H in. 70,9 / 78,7 / 86,6 W 35,4 D 29,1 H</p> <p>AES-25106 AES-25107 AES-25109</p> <p>AES-35106 AES-35107 AES-35109</p> <p>AES-25906 AES-25907 AES-25909</p>	<p>cm. 180 / 200 / 220 L 178 P 74 H in. 70,9 / 78,7 / 86,6 W 70,1 D 29,1 H</p> <p>AES-27406 AES-27407 AES-27409</p> <p>AES-47406 AES-47407 AES-47409</p> <p>AES-37406 AES-37407 AES-37409</p>	<p>cm. 88 L 56 P 74 H in. 34,6 W 22 D 29,1 H</p> <p>AES-52701</p>
<p>AES-67406 AES-67407 AES-67409</p> <p>AES-20406 AES-20407 AES-20409</p> <p>AES-30406 AES-30407 AES-30409</p> <p>AES-77406 AES-77407 AES-77409</p>		

ACCESSORI , ACCESSORIES , ACCESSOIRES , ACCESORIOS , АКССУАРЫ

<p>90 cm in. 35,4</p> <p>ES-5214090</p>	<p>178 cm in. 70,1</p> <p>ES-5214160</p>	<p>56 cm in. 22</p> <p>ES-5214056</p>	<p>180 &gt; 125 200 &gt; 145 220 &gt; 165</p> <p>ES-2501180 ES-2501200 ES-2501220</p>	<p>180 &gt; 85 200 &gt; 105 220 &gt; 125</p> <p>AES-50008 AES-50009 AES-50010</p>	<p>180 &gt; 105 200 &gt; 125 220 &gt; 145</p> <p>AES-50009 AES-50010 AES-50011</p> <p>28 cm in. 11</p>
<p>cm. 90 L 45 P 2 H in. 35,4 W 17,7 D 0,8 H</p> <p>C4-3005090</p>	<p>cm. 21,5 L 53,5 P 54 H in. 8,5 W 21,1 D 21,3 H</p> <p>MP-3701054</p>	<p>180 &gt; 110 200 &gt; 130 220 &gt; 150</p> <p>C4-1001140 C4-1001160 C4-1001180</p>	<p>C4-3716072</p>		

CONTENITORI , CABINETS , CONTENEURS , CONTENEDORES , КОНТЕЙНЕРЫ

<p>cm. 184 L 61 P 62 H in. 72,4 W 24 D 24,4 H</p> <p>AES-63006</p> <p>AES-63007</p> <p>AES-63008</p> <p>AES-63009</p>	<p>cm. 218 L 61 P 83 H in. 85,8 W 24 D 32,7 H</p> <p>AES-92842</p> <p>AES-92843</p> <p>AES-92844</p> <p>AES-92845</p>	<p>cm. 184 L 28 P 40 H in. 72,4 W 11 D 15,7 H</p> <p>ES-0721180</p>
---	---	---

CASSETTIERE , PEDESTALS , CAISSONS , BUCS , ТУМБОЧКИ

<p>cm. 42 L 60 P 56 H in. 16,5 W 23,6 D 22 H</p> <p>AES-60034</p>	<p>cm. 46 L 62 P 60 H in. 18,1 W 24,4 D 23,6 H</p> <p>AES-60042</p>	<p>AES-60334</p>	<p>AES-60342</p>	<p>ES-1112045</p>	<p>C4-4208035</p>
---	---	------------------	------------------	-------------------	-------------------

COMPLEMENTI , ACCESSORIES , COMPLEMENTS , COMPLEMENTOS , ДОПОЛНЕНИЯ

<p>cm. 90 L 90 P 74 H in. 35,4 W 35,4 D 29,1 H</p> <p>AES-30230</p>	<p>cm. 150 L 75 P 74 H in. 59,1 W 29,5 D 29,1 H</p> <p>AES-31006</p>	<p>cm. 184 L 61 P 74 H in. 72,4 W 24 D 29,1 H</p> <p>AES-31206</p>	<p>AES-31207</p>	<p>AES-31208</p>	<p>cm. 184 L 61 P 17 H in. 72,4 W 24 D 6,7 H</p> <p>AES-31808 : 17 / 6,7 H</p>
<p>cm. 60 L 60 P 35 H in. 23,6 W 23,6 D 13,8 H</p> <p>AES-31931</p>	<p>cm. 120 L 60 P 35 H in. 47,2 W 23,6 D 13,8 H</p> <p>AES-31903</p>	<p>A4C-99004</p>	<p>A4C-99005</p>		



TAVOLI , MEETING TABLES , TABLES , MESAS DE JUNTAS , СТОЛЫ

<p>cm. 240 L 115 P 74 H in. 94,5 W 45,3 D 29,1 H</p> <p>AES-30210      AES-40210      AES-60210</p>	<p>cm. 240 L 160 P 74 H in. 94,5 W 63 D 29,1 H</p> <p>AES-31310      AES-41310      AES-61310</p>
<p>cm. 160 / 200 / 240 L 115 P 74 H in. 63 / 78,7 / 94,5 W 45,3 D 29,1 H</p> <p>AES-31405 AES-31407 AES-31410</p>	<p>cm. 160 / 200 L 115 P 74 H in. 63 / 78,7 W 45,3 D 29,1 H</p> <p>AES-99004      AES-99104</p>
<p>cm. 160 / 200 / 240 L 160 P 74 H in. 63 / 78,7 / 94,5 W 63 D 29,1 H</p> <p>AES-31505 AES-31507 AES-31510</p>	<p>cm. 160 / 200 L 160 P 74 H in. 63 / 78,7 W 63 D 29,1 H</p> <p>AES-41505 AES-41507 AES-41510</p> <p>AES-31705 AES-31707</p> <p>AES-99006      AES-99106      AES-99008      AES-99108</p>

TOP ACCESS , CABLE LID , ACCES ELECTRIFICATION , TOP ACCESS , ЛЮК "TOP ACCESS"

<p>C4-1007026</p>	<p>C4-1012026</p>	<p>C4-4003032</p>	<p>C4-1008026</p>	<p>C4-4004016</p>	<p>C4-3723006</p>	<p>C4-3722006</p>	<p>C4-3724006</p>
-------------------	-------------------	-------------------	-------------------	-------------------	-------------------	-------------------	-------------------

DIVANI E COMPLEMENTI ATTESA , WAITING AND SOFAS , CANAPES ET COMPLEMENTES SALLES D'ATTENTE , SOFÁS Y COMPLEMENTOS ESPERA  
ДИВАНЫ И АКСЕССУАРЫ ДЛЯ ЗОН ОЖИДАНИЯ

<p>cm. 84 L 85 P 82 H in. 33,1 W 33,5 D 32,3 H</p> <p>A4C-98089</p>	<p>cm. 144 L 85 P 82 H in. 56,7 W 33,5 D 32,3 H</p> <p>A4C-98189</p>	<p>cm. 204 L 85 P 82 H in. 80,3 W 33,5 D 32,3 H</p> <p>A4C-98289</p>	<p>cm. 60 L 55 P 42 H in. 23,6 W 21,7 D 16,5 H</p> <p>A4C-98789</p>	<p>cm. 90 L 85 P 42 H in. 35,4 W 33,5 D 16,5 H</p> <p>A4C-98889</p>	<p>cm. 125 L 55 P 42 H in. 49,2 W 21,7 D 16,5 H</p> <p>A4C-98989</p>
<p>cm. 89 L 78 P 145 H in. 35 W 30,7 D 57,1 H</p> <p>A4C-98489</p>	<p>cm. 149 L 78 P 145 H in. 58,7 W 30,7 D 57,1 H</p> <p>A4C-98589</p>	<p>cm. Ø 80 x 32 H in. Ø31,5 x 12,6 H</p> <p>A4C-30001</p>	<p>cm. 120 L 60 P 32 H in. 47,2 W 23,6 D 12,6 H</p> <p>A4C-31303</p>		

ARMADI H. 82 , H. 82 CM STORAGE UNITS , ARMOIRES H. 82 , ARMARIOS H. 82 , ШКАФЫ H. 82

<p>cm. 45 L 45 P 82 H in. 17,7 W 17,7 D 32,3 H</p> <p>ACC-95001</p>	<p>cm. 45 L 45 P 82 H in. 17,7 W 17,7 D 32,3 H</p> <p>AES-95002 SX</p>	<p>cm. 45 L 45 P 82 H in. 17,7 W 17,7 D 32,3 H</p> <p>ES-0726082 DX</p>	<p>cm. 45 L 45 P 82 H in. 17,7 W 17,7 D 32,3 H</p> <p>AES-95004 DX</p>	<p>cm. 45 L 45 P 82 H in. 17,7 W 17,7 D 32,3 H</p> <p>AES-95005 SX</p>
<p>cm. 90 L 45 P 82 H in. 35,4 W 17,7 D 32,3 H</p> <p>ACC-95101</p>	<p>cm. 90 L 45 P 82 H in. 35,4 W 17,7 D 32,3 H</p> <p>AES-95108</p>	<p>cm. 90 L 45 P 82 H in. 35,4 W 17,7 D 32,3 H</p> <p>AES-95109</p>		





ARMADI H. 124 , H. 124 CM STORAGE UNITS , ARMOIRES H. 124 , ARMARIOS H. 124 , ШКАФЫ H. 124

<p>cm. 45 L 45 P 124 H in. 17,7 W 17,7 D 48,8 H</p> <p>ACC-95201</p>	<p>cm. 45 L 45 P 124 H in. 17,7 W 17,7 D 48,8 H</p> <p>AES-95204 DX</p>	<p>cm. 45 L 45 P 124 H in. 17,7 W 17,7 D 48,8 H</p> <p>AES-95205 SX</p>	<p>cm. 90 L 45 P 124 H in. 35,4 W 17,7 D 48,8 H</p> <p>ACC-95301</p>	<p>cm. 90 L 45 P 124 H in. 35,4 W 17,7 D 48,8 H</p> <p>AES-95308</p>	<p>cm. 90 L 45 P 124 H in. 35,4 W 17,7 D 48,8 H</p> <p>AES-95309</p>
--	---	---	--	--	--



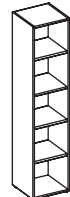

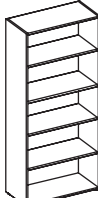
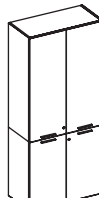
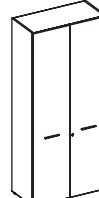
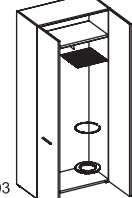





ARMADI H. 162 , H. 162 CM STORAGE UNITS , ARMOIRES H. 162 , ARMARIOS H. 162 , ШКАФЫ H. 162

<p>cm. 45 L 45 P 162 H in. 17,7 W 17,7 D 63,8 H</p> <p>ACC-95401</p>	<p>cm. 45 L 45 P 162 H in. 17,7 W 17,7 D 63,8 H</p> <p>AES-95410 DX</p>	<p>cm. 45 L 45 P 162 H in. 17,7 W 17,7 D 63,8 H</p> <p>AES-95411 SX</p>	<p>cm. 45 L 45 P 162 H in. 17,7 W 17,7 D 63,8 H</p> <p>AES-95404 DX</p>	<p>cm. 45 L 45 P 162 H in. 17,7 W 17,7 D 63,8 H</p> <p>AES-95405 SX</p>
<p>cm. 90 L 45 P 162 H in. 35,4 W 17,7 D 63,8 H</p> <p>ACC-95501</p>	<p>cm. 90 L 45 P 162 H in. 35,4 W 17,7 D 63,8 H</p> <p>AES-95508</p>	<p>cm. 90 L 45 P 162 H in. 35,4 W 17,7 D 63,8 H</p> <p>AES-95503</p>	<p>cm. 90 L 45 P 162 H in. 35,4 W 17,7 D 63,8 H</p> <p>AES-95516</p>	<p>cm. 90 L 45 P 162 H in. 35,4 W 17,7 D 63,8 H</p> <p>AES-95509</p>



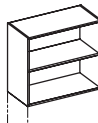
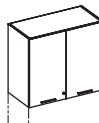

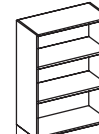
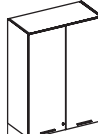









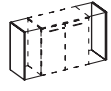
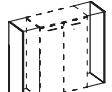
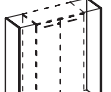
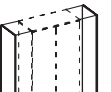

ARMADI H. 204 , H. 204 CM STORAGE UNITS , ARMOIRES H. 204 , ARMARIOS H. 204 , ШКАФЫ H. 204

<p>cm. 45 L 45 P 204 H in. 17,7 W 17,7 D 80,3 H</p>  <p>ACC-95601</p>  <p>AES-95610 DX</p>  <p>AES-95611 SX</p>			
<p>cm. 90 L 45 P 204 H in. 35,4 W 17,7 D 80,3 H</p>  <p>ACC-95701</p>  <p>AES-95722</p>  <p>AES-95708</p>  <p>AES-95703</p>  <p>AES-95716</p>  <p>AES-95723</p>			

ARMADI SOPRALZO , CABINETS OVER STORAGE UNITS , ARMOIRES SUPERPOSABLES , ALZADAS , ШКАФЫ-НАДСТРОЙКИ

<p>cm. 45 L 45 P 80 H in. 17,7 W 17,7 D 31,5 H</p>  <p>ACC-95901</p>  <p>AES-95904 DX</p>  <p>AES-95905 SX</p>	<p>cm. 45 L 45 P 122 H in. 17,7 W 17,7 D 48 H</p>  <p>ACC-96101</p>  <p>AES-96104 DX</p>  <p>AES-96105 SX</p>
<p>cm. 90 L 45 P 80 H in. 35,4 W 17,7 D 31,5 H</p>  <p>ACC-96001</p>  <p>AES-96008</p>  <p>AES-96009</p>	<p>cm. 90 L 45 P 122 H in. 35,4 W 17,7 D 48 H</p>  <p>ACC-96201</p>  <p>AES-96208</p>  <p>AES-96209</p>

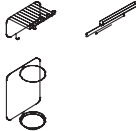
COMPLEMENTI ARMADI , STORAGE UNITS ACCESORIES , COMPLÉMENTS POUR ARMOIRES , ACCESORIOS PARA ARMARIOS , ДОПОЛНЕНИЯ ДЛЯ ШКАФОВ

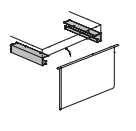
<p>cm. 45 L 45 P 2 H in. 17,7 W 17,7 D 0,8 H</p>  <p>MP-1212045</p>	<p>cm. 90 L 45 P 2 H in. 35,4 W 17,7 D 0,8 H</p>  <p>MP-1212090</p>	<p>cm. 135 L 45 P 2 H in. 53,1 W 17,7 D 0,8 H</p>  <p>MP-1212135</p>	<p>cm. 180 L 45 P 2 H in. 70,9 W 17,7 D 0,8 H</p>  <p>MP-1212180</p>	<p>cm. 225 L 45 P 2 H in. 88,6 W 17,7 D 0,8 H</p>  <p>MP-1212225</p>	<p>cm. 270 L 45 P 2 H in. 106,3 W 17,7 D 0,8 H</p>  <p>MP-1212270</p>
<p>cm. 4 L 46 P 82 H in. 1,6 W 18,1 D 32,3 H</p>  <p>MP-1512082</p>	<p>cm. 4 L 46 P 122 H in. 1,6 W 18,1 D 48 H</p>  <p>MP-1512122</p>	<p>cm. 4 L 46 P 162 H in. 1,6 W 18,1 D 63,8 H</p>  <p>MP-1512162</p>	<p>cm. 4 L 46 P 204 H in. 1,6 W 18,1 D 80,3 H</p>  <p>MP-1512202</p>		
<p>cm. 90 L 2 P 82 H in. 35,4 W 0,8 D 32,3 H</p>  <p>MP-2722082</p>	<p>cm. 90 L 2 P 124 H in. 35,4 W 0,8 D 48,8 H</p>  <p>MP-2722122</p>	<p>cm. 90 L 2 P 162 H in. 35,4 W 0,8 D 63,8 H</p>  <p>MP-2722162</p>	<p>cm. 90 L 2 P 204 H in. 35,4 W 0,8 D 80,3 H</p>  <p>MP-2722202</p>		
<p>cm. 45 L 2 P 82 H in. 17,7 W 0,8 D 32,3 H</p>  <p>MP-2721082</p>	<p>cm. 45 L 2 P 124 H in. 17,7 W 0,8 D 48,8 H</p>  <p>MP-2721122</p>	<p>cm. 45 L 2 P 162 H in. 17,7 W 0,8 D 63,8 H</p>  <p>MP-2721162</p>	<p>cm. 45 L 2 P 204 H in. 17,7 W 0,8 D 80,3 H</p>  <p>MP-2721202</p>	 <p>C4-3963000</p>  <p>C4-3715086</p>  <p>C4-3962086</p>	



Il sistema Qualità Uffix è certificato secondo la norma ISO 9001.  
I prodotti Uffix sono testati presso il laboratorio prove CATAS.  
I prodotti Uffix sono testati secondo le normative UNI.  
I prodotti Uffix sono conformi al D.L. 81/08



Uffix's quality system is certified according to the ISO 9001 norm.  
Uffix products are tested in the CATAS tests laboratory.  
Uffix products are tested according to UNI norms.  
Uffix products are in conformity with the law D.L. 81/08 .



Le système qualité Uffix est certifié selon la normative ISO 9001.  
Les produits Uffix sont testés chez le laboratoire des essais CATAS.  
Les produits Uffix sont testés selon les normes UNI.  
Les produits Uffix sont conformes à la loi D.L. 81/08

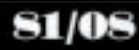

El sistema Calidad Uffix está certificado según la normativa ISO 9001.  
Los productos Uffix están testados por el laboratorio de pruebas CATAS.  
Los productos Uffix están testados según las normativas UNI.  
Los productos Uffix son conformes al D.L. 81/08

Система Качества Компании Uffix сертифицирована по стандарту ISO 9001.  
Продукция Компании Uffix тестируется в испытательной лаборатории CATAS.  
Продукция Компании Uffix тестируется в соответствии со стандартом UNI.  
Продукция Компании Uffix соответствует D.L. 81/08



---

© Uffix S.r.l. - Edizione Luglio 2015

Tutti i diritti riservati: Uffix si riserva di apportare le modifiche ritenute necessarie senza obbligo di preavviso. Immagini e rese cromatiche sono soggette alle rese di stampa. Dati e misure non sono vincolanti. Vietata la riproduzione anche parziale. I marchi citati nel presente catalogo sono di proprietà delle rispettive società.

© Uffix S.r.l. - July 2015 Edition

All rights reserved: Uffix is entitled to do the necessary modifications without any notice. Images and colour rendering may change according to the printer used. Data and dimensions are not binding. The reproduction, even if partial, is forbidden. The brands listed in the present catalogue belong to the respective companies.

© Uffix S.r.l. - Edition Juillet 2015

Tous droits réservés: Uffix se réserve le droit d'apporter les modifications nécessaires sans obligation d'en aviser sa clientèle. Les images et rendus chromatiques sont sujets aux rendus d'impression. Les descriptions et mesures ne sont pas contractuelles. Reproduction totale ou partielle interdite. Les marques citées dans ce catalogue appartiennent aux respectives sociétés.

© Uffix S.r.l. - Edición Julio 2015

Todos los derechos reservados: Uffix se reserva el derecho de efectuar las modificaciones necesarias sin previo aviso. Imágenes y efectos cromáticos dependen de la calidad de la impresión. Datos y medidas no son vinculantes. No se admite la reproducción ni parcial. Las marcas indicadas en el presente catálogo son de propiedad de las respectivas sociedades.

© Уффикс С.р.л. - Июль 2015

Защищенные права: Уффикс оставляет за собой право вносить, по своему усмотрению, в случае необходимости, изменения без предварительного уведомления. Фотографии и их цветовая гамма – в соответствии с характеристиками печати. Характеристики и размеры могут быть изменены. Копирование, в том числе и частичное, запрещено. Упомянутые торговые марки в настоящем каталоге являются собственностью данной фирмы.

---

Product Design \_ Franco Driusso - DriussoAssociati I Architects  
Product Engineering \_ CRS Uffix  
Art Direction \_ DriussoAssociati I Architects  
Graphic Design \_ DriussoAssociati I Architects  
Photo \_ Andrea Pancino  
Images Production \_ NeroKubo  
Print \_ Grafiche Antiga

Thanks to \_ Luisa Canovi Origami DO

**uffix**<sup>®</sup>

Uffix S.r.l.  
Via Pontal 13  
33087 Pasiano (PN)  
ITALY  
Tel. +39.0434.625291  
Fax +39.0434.625979  
info@uffix.com  
www.uffix.com